



UP FOR  
ANYWHERE



*SNARLER*

AT6 S  
AT6 L

USER MANUAL

# WELCOME

Thank you for buying Segway ATV.

Segway Off-road vehicles will bring you a  
new driving experience.

For your driving safety, please read this manual before riding. This manual contains important safety instructions, operation instructions, maintenance instructions and safety warnings.

A careful reading of this manual will help you to quickly understand the vehicle and will help your driving.

Periodic maintenance procedures are included in this manual. They must be performed regularly to maintain vehicle's safety.

## **WARNING**

Read, understand, and follow all of the instructions and safety precautions in this manual and all product labels.

Failure to follow the safety precautions could result in serious injury or death.

# IMPORTANT NOTICE

This vehicle is designed and manufactured for off-road use and complies with all applicable off-road noise, vibration and emission regulations.

Before driving the vehicle, please understand the local laws and regulations, follow local traffic regulations.

This manual is applicable to the Segway ATV fuel series and describes all equipment including optional components. Therefore, some of the optional equipment described in the manual may be not installed on your vehicle.

If your vehicle needs service or repair, please contact our dealer. He will provide you professional service in a timely manner. All specifications provided in this manual are up to date at the time of printing. However, due to continuous product improvement, the contents of this manual can be updated at any time without prior notice. The descriptions and/or procedures in this manual are for informational purposes only. We take no responsibility for omissions or inaccuracies. Express prohibition or reuse of descriptions and/or programs contained in whole or in part.

# TABLE OF CONTENTS

<b>SAFETY INTRODUCTION</b>	<b>8</b>
<b>VEHICLE DEVICE</b>	<b>30</b>
<b>OPERATION</b>	<b>75</b>
<b>MAINTENANCE</b>	<b>107</b>
<b>SPECIFICATIONS</b>	<b>173</b>
<b>TROUBLESHOOTING</b>	<b>181</b>
<b>EMISSION CONTROL SYSTEM</b>	<b>190</b>

# INTRODUCTION

## BEFORE YOU RIDE

This Segway ATV is an off-road vehicle. Familiarize yourself with all laws and regulations concerning the operation of this vehicle in your area.



### WARNING

- ◆ Failure to observe warnings and safety precautions in this manual can result in severe injury or death. Your Segway ATV is not a toy and can be hazardous to operate. ATVs handle differently from cars, trucks or the off-road vehicles. A collision or rollover can occur quickly, even during routine maneuvers like turning, driving on hills or over obstacles, if you fail to take proper precautions.
- ◆ Read this manual that came with your vehicle. Understand all safety warnings, precautions and operating procedures before operating the vehicle. Keep this manual with the vehicle.
- ◆ Never operate this vehicle without proper instruction.

- ◆ This vehicle is an ADULT VEHICLE ONLY. You MUST be at least of age 16 and have a valid driver's license to operate this vehicle.
- ◆ Always wear a helmet, eye protection, gloves, long- sleeve shirt, long pants and over-the-ankle boots.
- ◆ Never consume alcohol or drugs before or while operating this vehicle, as these they impair judgment and reduce the operator's ability to react.
- ◆ Complete the New Operator Driving Procedures outlined this manual. Never allow a other person to operate this vehicle until he/she has completed the New Operator Driving Procedures.
- ◆ Never permit other person to operate this vehicle unless he/she has read this owner's manual and all safety labels, and has completed safety training.

# The meaning of the signs :

## **WARNING**



Failure to follow **WARNING** instructions could result in severe injury or death to the operator, a bystander or a person inspecting or repairing the machine.

## **CAUTION**

**YOU CAN** be **HURT** if you don't follow these instructions.

## **NOTE**

**NOTE** provides key information by clarifying instructions.

<p>The Prohibition Safety Sign indicates an action <b>NOT</b> to take in order to avoid a hazard.</p>		<p>The Must Action Sign indicates an action that <b>NEEDS</b> to be taken to avoid a hazard.</p>	
---	---	--	---

# SAFETY INTRODUCTION

<b>WARNING LABELS .....</b>	<b>11</b>
<b>GENERAL SAFETY PRECAUTIONS .....</b>	<b>18</b>
<b>IMPORTANT SAFETY INFORMATION ...</b>	<b>22</b>
Reading the manual .....	22
Safe driving age.....	23
Riding equipment .....	24
Vehicle modifications .....	26
Passengers .....	27
Exhaust gases are dangerous .....	28
Fuel safety .....	29



Failure to follow the warnings and safety precautions in this manual may result in serious injury or death. It can be dangerous to operate an ATV that is not regulated and drives differently from other vehicles, such as motorcycles and cars. If proper precautions are not taken, a collision or roll-over may occur during normal maneuvers such as turning, driving on hills or over obstacles. Understand all safety warnings, precautions and operating procedures before operating this vehicle. Bring this manual with you.

## **WARNING LABELS**

Warning labels have been placed on the vehicle for your protection. Read and follow the instructions on the labels carefully. If any of the labels depicted in this manual differ from the labels on your vehicle, always read and follow the instructions on the vehicle. If any label becomes unreadable or comes off, contact your Segway Powersports dealer for a replacement.

Model: AT6 S

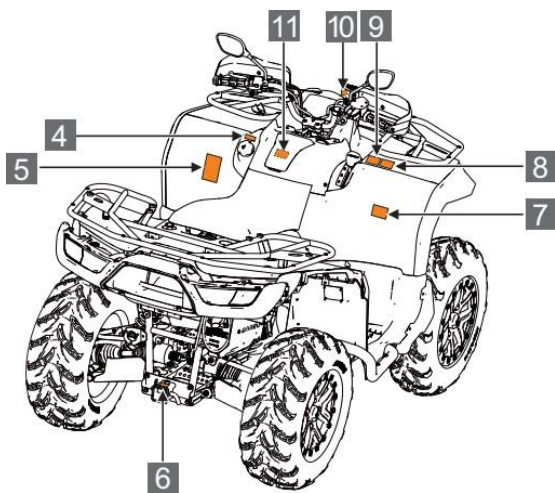
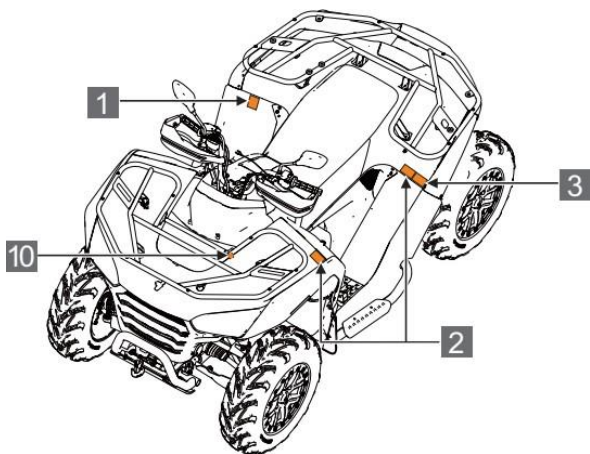

Model: AT6 L

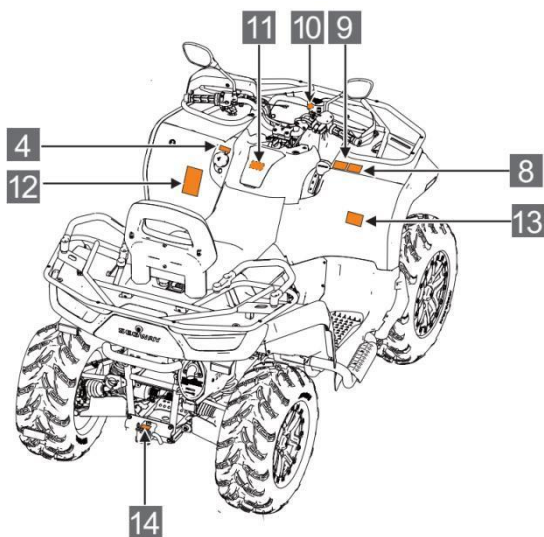
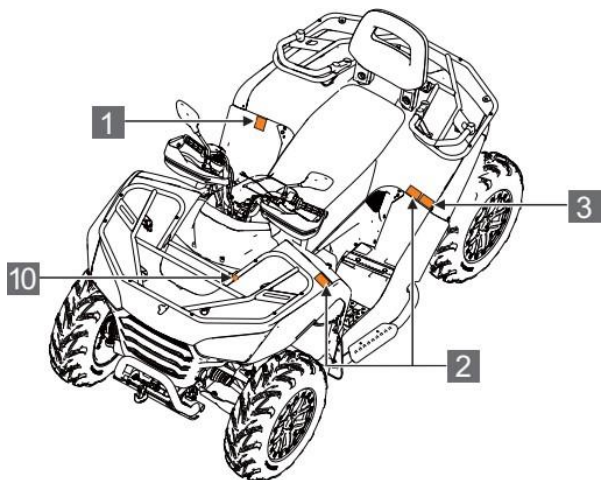

61

**⚠ WARNING**

Improper ATV use can result in SEVERE INJURY  
or DEATH



ALWAYS USE  
AN APPROVED  
HELMET AND  
PROTECTIVE  
GEAR



NEVER CARRY  
PASSENGERS



NEVER USE  
WITH DRUG!  
OR ALCOHOL

**NEVER** operate

- Without proper training or instruction.
- At speeds too fast for your skills or the conditions.
- On public roads—a collision can occur with another vehicle.
- With a passenger—passengers affect balance and steering and increase risk of losing control.

**ALWAYS:**

- Use proper riding techniques to avoid vehicle overturns on hills and rough terrain and in turns
- Avoid paved surfaces—pavement may seriously affect handling and control.

**LOCATE AND READ OWNER'S MANUAL.  
FOLLOW ALL INSTRUCTIONS AND WARNINGS!**

6



7

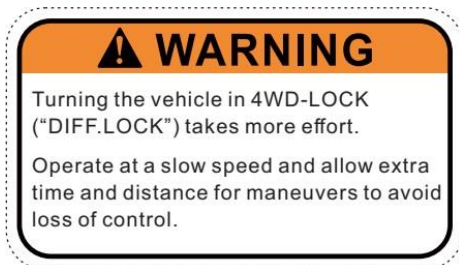

8

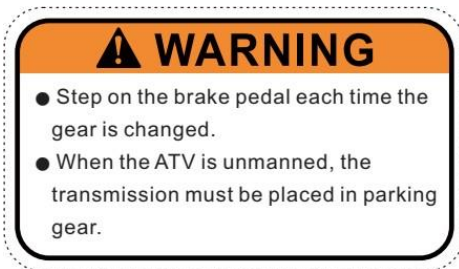

9



10

**CAUTION**

The air filter must be maintained in accordance with the requirements of the Segway «Owner's Manual» otherwise it may seriously damage your engine.

11

**⚠ WARNING**

Improper ATV use can result in SEVERE INJURY or DEATH



ALWAYS USE  
AN APPROVED  
HELMET AND  
PROTECTIVE  
GEAR



NEVER CARRY  
PASSENGERS



NEVER USE  
WITH DRUGS  
OR ALCOHOL

**NEVER** operate

- Without proper training or instruction.
- At speeds too fast for your skills or the conditions.
- On public roads-a collision can occur with another vehicle.
- With a passenger-passengers affect balance and steering and increase risk of losing control.

**ALWAYS:**

- Use proper riding techniques to avoid vehicle overturns on hills and rough terrain and in turns
- Avoid paved surfaces-pavement may seriously affect handling and control.

**LOCATE AND READ OWNER'S MANUAL.  
FOLLOW ALL INSTRUCTIONS AND WARNING!**

12





## GENERAL SAFETY PRECAUTIONS

**SEVERE INJURY OR DEATH can result if you do not follow these instructions:**

- ◆ Minimum recommended driving age for this vehicle is 16 years.
- ◆ Never operate this vehicle without wearing an approved motorcycle helmet that fits properly. You should also wear eye protection (goggles or a face shield), gloves, over-the-ankle boots, long-sleeved shirt or jacket, and long pants.
- ◆ Never consume alcohol or drugs before or while operating this vehicle.
- ◆ Never attempt jumps, wheelies or other stunts.
- ◆ Never operate at speeds too fast for your skills or the conditions. Always go at a speed that is proper for the terrain, visibility, operating conditions and your experience.
- ◆ Always inspect your vehicle every time you use it to be sure it is in safe operating condition.
- ◆ Never operate on excessively rough, slippery, or

loose terrain until you have learned and practiced the skills necessary to control the vehicle in such terrain. Always be especially cautious on these kinds of terrain.

- ◆ Always follow the inspection and maintenance procedures and schedules described in this manual.
- ◆ Never operate on hills that are slippery or ones where you will not be able to see far enough ahead of you. Never go over the top of a hill at speed if you cannot see what is on other side.
- ◆ Always keep hands, arms, feet, and legs inside the vehicle at all times during operation. Keep your feet on the floorboard. Never hold onto the enclosure. Otherwise, your hands could be injured if it is caught between the enclosure and an obstacle outside the vehicle.
- ◆ Always keep both hands on the handlebars when driving.
- ◆ Always go slowly and be extra careful when operating on unfamiliar terrain. Always be alert to changing terrain conditions when driving.
- ◆ Never turn at excessive speed. Practice turning at

slow speeds before attempting to turn at faster speeds. Do not attempt turns on steep inclines.

- ◆ Always follow proper procedures when going uphill. If you lose control and cannot continue up a hill, back down the hill with the engine in reverse gear. Use engine braking to help you to slow down. If necessary, use the brakes gradually to help you go slowly.
- ◆ Never operate the vehicle on hills that are too steep for it or for your abilities. Go straight up and down the hills where possible.
- ◆ Never operate the vehicle in fast flowing water or water deeper than the floorboards on this model. Remember that wet brakes may have reduced stopping ability. Test your brakes after leaving water. If necessary, apply the brake several times to let friction dry out the linings.
- ◆ Always be sure there are no obstacles or people behind you when you operate in reverse. When it is safe to proceed in reverse, go slowly.
- ◆ Always check the terrain before going downhill. Go as slowly as possible. Never go down a hill at high

speed.

- ◆ Always check for obstacles before operating in a new area.
- ◆ Do not brake abruptly when carrying loads.
- ◆ Always use the size and type of tires specified in this manual.
- ◆ Always maintain proper tire pressure as described in this manual.
- ◆ Never exceed stated load capacity. Cargo should be distributed evenly on front and rear rack. Be sure that cargo is secured so that it cannot move around during the ride. Reduce speed and follow instructions in this manual for carrying cargo or pulling a trailer. Allow greater distance for braking.
- ◆ Brake discs can be over-heated after continuous braking. Allow brake disc to cool before serving.
- ◆ Risks related to contact with hot surfaces, including residual risks such as filling of oil or coolant, hot engines or transmissions.

## IMPORTANT SAFETY INFORMATION

### Reading the manual

#### **▲ WARNING**

Driving an ATV improperly increases the risk of accident. The driver must know how to drive the vehicle correctly in different situations and on different terrain.

Before driving the vehicle, all drivers must complete the required driving safety training. Please ensure that each driver has read this manual and all product warning labels and has passed the safety training course. Otherwise, the vehicle will not be allowed to drive.



## Safe driving age

### **▲ WARNING**

The minimum recommended age for driving this vehicle is 16 years. Children under the age of 16 must not drive this vehicle. Do not drive the vehicle without proper driving training; training courses are required. Please ensure that every driver has read this manual and all Warning labels and has completed a safety training course.



## Riding equipment

### **WARNING**

For your safety, we strongly recommend you to always wear an approved motorcycle helmet, eye protection, boots, gloves, long pants, and a long-sleeved shirt or jacket whenever you ride. Although 100% protection is not possible, wearing proper gear can reduce the chance of injury when you ride.

### **Helmet**

Wearing a helmet can prevent head injuries. When driving, you must wear an approved helmet that meets safety standards ECE 22.05.

### **Additional Riding Gear**

Sturdy off-road motorcycle boots will help protect your feet, ankles, and lower legs.

Off-road motorcycle gloves will protect your hands.

Riding pants with knee and hip pads, riding jersey with padded elbows, and a chest/shoulder protector will help protect your body.

**▲ WARNING**

Driving ATV after drinking or taking drugs may adversely affect a driver's judgment, reaction time, balance, and senses. Do not drink alcohol or take drugs before or during driving.

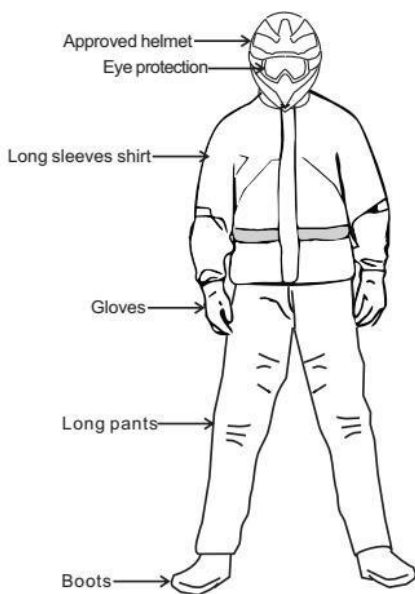



## Vehicle modifications

### **▲ WARNING**

We strongly recommend you not to attempt to increase vehicle speed or use any equipment that increases the power of the vehicle. If any equipment is added to the vehicle, or if any modifications are made to the vehicle to increase the vehicle speed or power, the warranty may be influenced. The addition of certain accessories may change the handling of the vehicle, including (but not limited to) mowers, sledges, tires, sprayers, or large luggage racks.



## Carrying passengers



### WARNING

Riding with passenger largely reduces driver's ability to control an ATV, which can lead to accidents or rollovers. Do not ride with this ATV carrying more riders / passengers than is this vehicle designed for.

Never carry more passengers than your vehicle is designed for.



## Exhaust gases are dangerous

### ▲ WARNING

Exhaust gas is toxic and can cause loss of consciousness or death in a short time. Do not start or run a motor in a closed space. The engine exhaust of this product contains chemicals that can cause cancer, birth defects or other reproductive damage. You can only start it outside the room or in a well-ventilated area.



## Fuel safety

### **WARNING**

#### **Gasoline is flammable!**

- ◆ Be extremely careful when dealing with gasoline.
- ◆ When refueling, the engine must be shut off and must be done outdoors or in a well-ventilated area.
- ◆ At, or near the refueling or gasoline storage place do not smoke, avoid open flame or sparks.
- ◆ Do not overflow the tank when refueling. Do not fill the tank up to the neck.
- ◆ If gasoline gets on your skin or clothes, wash them with soap and water immediately and change clothes.

# VEHICLE DEVICE

<b>VEHICLE ACTIVATION...</b>	<b>32</b>
First activation.....	32
<b>APPFUNCTION.....</b>	<b>35</b>
<b>FEATURES AND CONTROLS .....</b>	<b>36</b>
Location of parts and controls .....	36
Handlebar switches .....	37
Ignition switch .....	38
Engine Start/Stop switch .....	39
Headlight switch.....	40
Turn signal switch.....	41
Hazard Switch.....	42
Force-multiplier / Override switch.....	43
Winch controller .....	44
Drive select switch .....	45
Throttle lever .....	50
12V Accessory outlet / USB Port.....	51
Shifting .....	52

# VEHICLE DEVICE

Parking brake.....	53
Parking brake lever free play.....	54
Foot brake.....	55
Front (auxiliary) brake.....	57
Fuel tank cap.....	58
Storage box.....	59

## **INSTRUMENTS..... 60**

Indicators / Warning lights... ..	61
LCD Display .....	64
Diagnostic trouble codes.....	67
Display Setting.....	73

## **HANDLEBARS ADJUSTMENT... .. 74**

# VEHICLE ACTIVATION

This vehicle is equipped with DTS system. DTS is used to communicate between vehicle systems and mobile APP to obtain vehicle information and to control the vehicle with your mobile APP. To make you familiar with and use the system, please read the User manual carefully and understand the application operation.

## NOTE

**New vehicle must be activated through the APP for the first time. Otherwise vehicle will not start.**

## First Activation

Download the APP from the “APP Store” in your mobile phone before you try to activate the ATV for the first time. Search for “**Segway Powersports**” in the APP Store in your mobile phone, and then download the APP.

After successful installation, your vehicle can be registered and activated. First, locate the VIN number on the vehicle and register it to the APP.

The registration procedure is as follows:

1. Power-up the vehicle with the key;

Input or scan vehicle's VIN number as the APP prompts you, and step on the foot brake at the same time.

**Note:**

If the VIN number cannot be scanned by the phone, for example due to the low light, you can enter the VIN number manually. The vehicle VIN number you will find on the frame (see Page 179) and on the Identification plate (see Page 180).

2. Complete the registration and activate the connection;
3. Start the engine.



## Vehicle activation

There are 3 ways to activate your vehicle:

1. **With the vehicle key (preferred)**
2. **Keyless activation via the APP**

Keyless APP unlocking is based on 4G network. As long as your area is covered with the 4G network, you can activate your vehicle via the APP.

3. **Keyless activation via Bluetooth**

When both vehicle and your mobile phone are within the Bluetooth distance, the vehicle Bluetooth module will automatically activate the vehicle when receiving Bluetooth signal of your mobile phone, and automatically switch off the vehicle when your mobile phone gets away.

### NOTE

After switching off the vehicle with the key, it cannot be activated again by the phone. You need to disconnect the phone and reconnect it to the vehicle to activate.

Ignition key is the optimal activation method for your vehicle. If you don't want to use the remote activation function, you can switch this possibility off in the APP.

# APP FUNCTION

**Main features:**

Driving control analysis, vehicle data analysis etc.

For detailed information please see the APP User Manual.

# FEATURES AND CONTROLS

Location of parts and controls

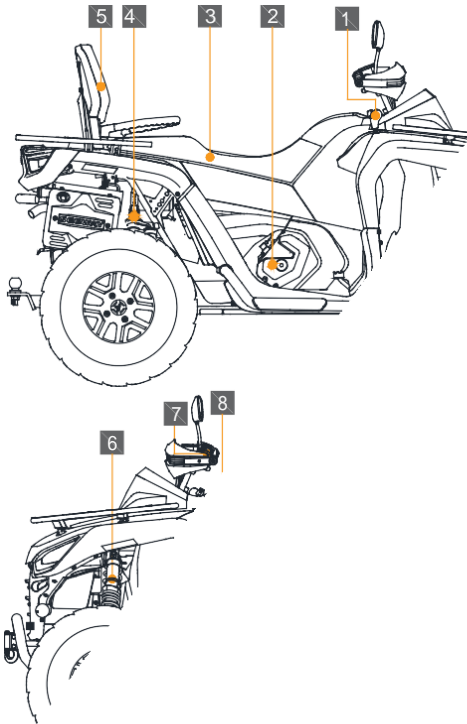

**1** Shift Lever

**2** Engine

**3** Seat

**4** Rear Shock Absorber

**5** Backrest

**6** Front Shock  
Absorber

**7** Handlebar Switch

**8** Fuel tank cap

## Handlebar switches

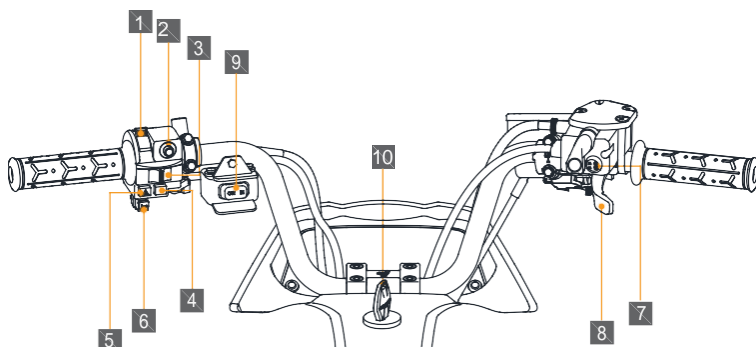

- |                                |                             |
|--------------------------------|-----------------------------|
| <b>1</b> Headlight Switch      | <b>2</b> Starter Button     |
| <b>3</b> Turn Signal Switch    | <b>4</b> Engine Stop Switch |
| <b>5</b> Emergency Stop Switch | <b>6</b> Horn Switch        |
| <b>7</b> Drive Select Switch   | <b>8</b> Throttle lever     |
| <b>9</b> Winch Switch          | <b>10</b> Ignition Switch   |

## Ignition Switch

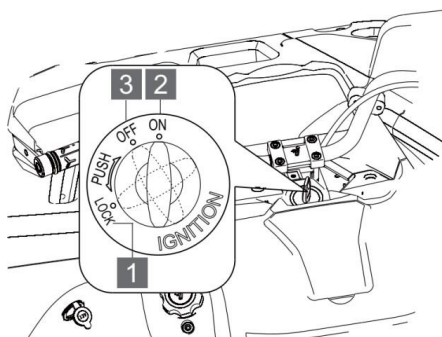

**1 Steering Lock**

**2 ON**

**3 OFF**

The ignition lock is located in the centre of the handlebars.

**“LOCK”** position:

Steering is locked in this position.

**“ON”** position:

All electrical circuits are on, all electrical systems are working. The key cannot be removed in this position.

**“OFF”** position:

All electrical circuits are off. The key can be removed.

## Engine start/stop switch

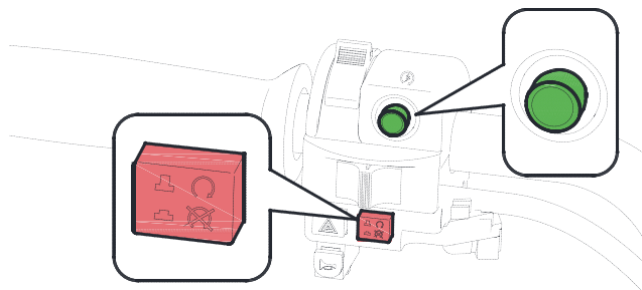

**1 Engine start button (Green)**

**2 Engine stop button (Red)**

### Starting the engine:

1. Step on the foot brake;  
Turn the ignition key into "ON" position. (see Page 38)
2. Press the Engine start button (green), the engine will start;

### To stop the engine:

Press the Engine stop button (red) to stop the engine.

## Headlight switch

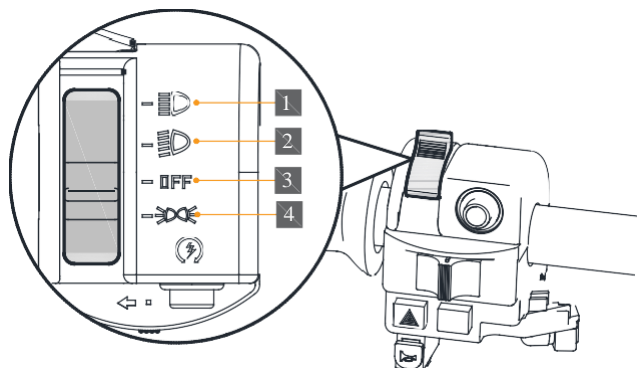

### 1 High Beam

Select to turn on the High Beam. The "H" indicator on the instrument panel will lit;

### 2 Low Beam

Select to turn on Low Beam ;

### 3 Lights off

### 4 Position lights

Turn on the position light, and the "P" indicator on the instrument panel will lit;

When the ignition switch is "ON", push the Position lights switch to the desired position. To turn the lights off, move the switch to the "OFF" position.

## Turn Signal Switch

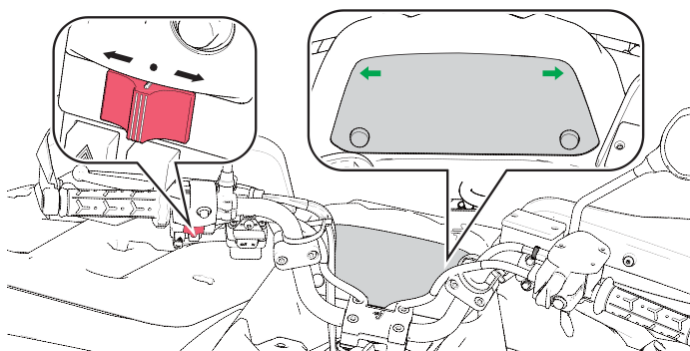

- ← Slide to the left to turn left turn signal on.  
The " ← " indicator on instrument panel flashes.
- Slide to the right to turn right turn signal on.  
The " → " indicator on instrument panel flashes.
- Turn off the turn signal by returning the switch to the central position.



## Hazard Switch

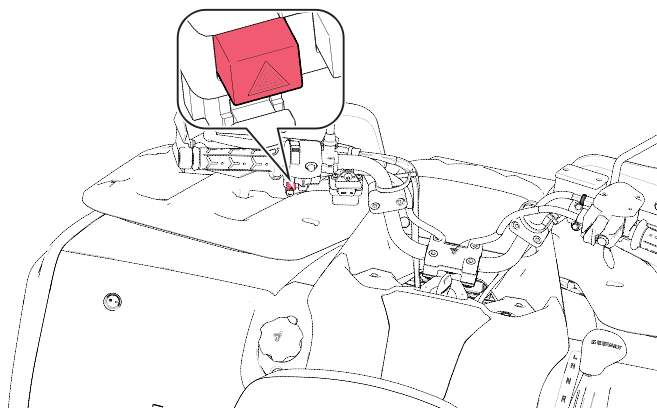



Press this switch to activate hazard warning lights in an emergency. Press again to deactivate hazard warning lights. When the hazard warning lights are on, all turn signal lights and both turn signal indicators on the instrument panel are flashing.

When to use hazard warning lights:

- ◆ **When temporary parking the vehicle**
- ◆ **In case of vehicle failure**
- ◆ **When the vehicle encounters other emergency**

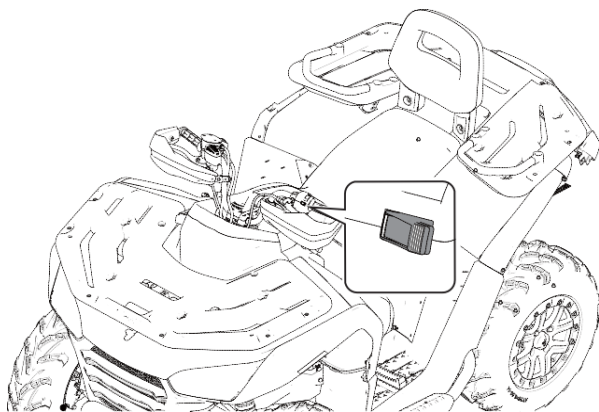
## Force-multiplier / Override switch



When the vehicle is in 4x4 mode ( instrument panel shows “” symbol, details see Page 46 ) or in 4x4 Locked mode (instrument panel shows “” symbol, details see Page 46), or in reverse, the vehicle speed is limited. Anyway, if you need more engine power in muddy conditions, on the hill or in other troubles, you can keep pressing this switch, and the vehicle will increase the speed limit and engine power, so it can help you to get out of the trouble.

### **WARNING!**

Improper use of Force-multiplier / Override button can lead to loss of control resulting in severe injury or death. Do not activate override while throttle is engaged.

## Winch controller

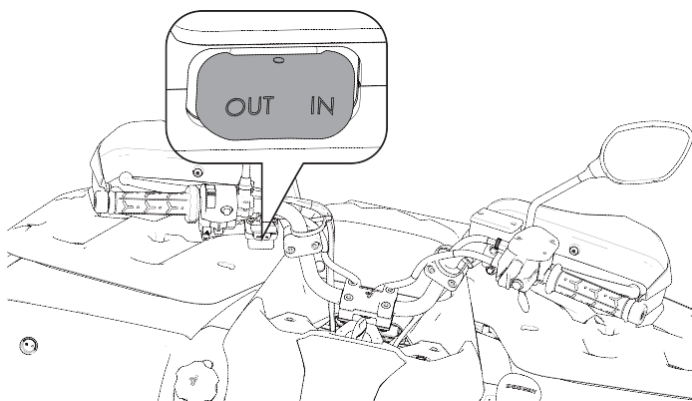

**OUT : Pull out the winch cable**

**IN : Winch in the winch cable**

ATV winch is used to pull vehicles out of mud, snow, sand, water, and over obstacles, and to control ATV accessories such as snow plow. Understand the correct methods how to use the winch. Pay attention to the safety warnings. Refer to the winch instructions and other items that need your attention ( see Page 101).

## Drive Select Switch

### Models with rear final drive

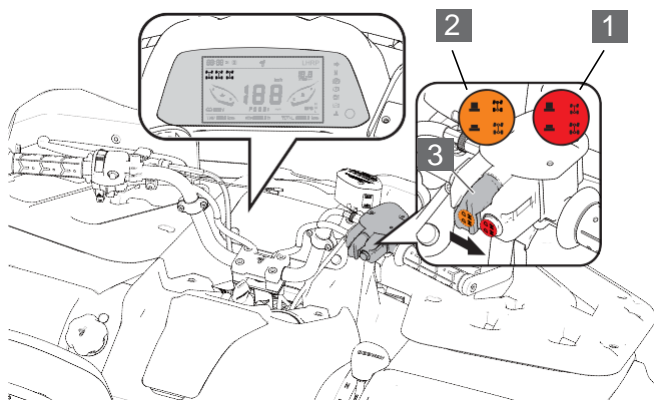

**1 Drive Select Switch**

**2 Front differential lock**

**3 Selection lever**

Models with rear final drive (no rear differential) are equipped with 2x4 (rear wheel drive only) and 4x4 (all wheel drive) drive mode switch. Select the appropriate 2x4 / 4x4 drive mode according to the situation and current terrain conditions. In addition, you can lock the front differential.

#### **Note:**

The selection lever can only be shifted into the Differential Lock position if the drive select switch is in the 4x4 position.

## 2 x 4 Mode

When the drive select switch is in 2x4 mode, vehicle is driven by the rear wheels only. The LCD gauge shows "  " symbol. Select this mode for riding on flat, dry, hard surfaces, and on the road.

## 4 x 4 Mode

When the 4-wheel mode is selected on the Drive Select Switch, power is supplied to the rear wheels and to the front wheels. "  " symbol is displayed on the LCD gauge. The vehicle will limit maximum speed to 30 km/h. This mode is suitable for rough terrain, muddy or hilly conditions and other difficult conditions.

## 4×4 Lock Mode

When you select Locked 4-wheel drive mode on Drive Select Switch, the four-wheel drive lock symbol "  " is displayed on the LCD gauge. Power is supplied to the rear and front wheels and the front differential is locked. Left and right front wheels turn at the same speed. Speed is limited 30 km/h. This mode is suitable if you get into troubles.

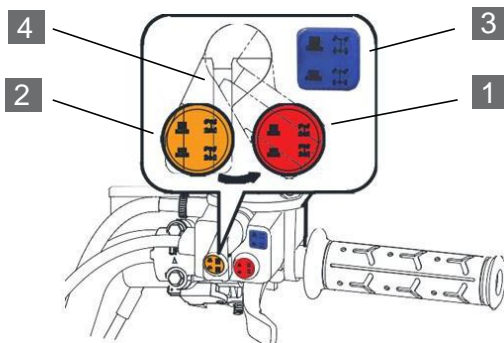
**Models with rear differential****1 Drive Select Switch****2 Front differential lock****3 Rear differential lock****3 Selection lever**

Models with rear differential are equipped with 2x4, 4x4, 2x4 LOCK and 4x4 LOCK drive modes. Depending on the situation, you can select the most suitable drive mode for you - see page 48.

**Note:**

The selection lever can only be shifted into the Differential lock position if the drive select switch is in the 4x4 position.

**WARNING!**

Operating the drive select switch while driving can be dangerous. Changing the drive mode while driving can cause sudden unexpected change in behavior of the ATV.

**WARNING!**

Changing the drive mode while driving can damage the transmission mechanism. Always stop completely before changing the drive mode.

## Drive mode selection - models with the rear differential

### 2x4 - Rear wheel drive

When to use	Driven wheels	Note
<ul style="list-style-type: none"> <li>• Normal driving on a level surface</li> <li>• In light terrain</li> <li>• On hard surfaces</li> <li>• When driving on roads</li> </ul>	<ul style="list-style-type: none"> <li>• Only the rear wheels are driven</li> <li>• Rear differential is active</li> <li>• Rear wheels turn at different speeds in corners</li> </ul>	<ul style="list-style-type: none"> <li>• Saves tires</li> <li>• Terrain, ground and grass friendly</li> </ul>

### 2x4 LOCK - Rear wheel drive with locked rear differential

When to use	Driven wheels	Note
<ul style="list-style-type: none"> <li>• On gravel and unpaved surfaces</li> <li>• In difficult terrain</li> <li>• If you need power on both rear wheels</li> </ul>	<ul style="list-style-type: none"> <li>• Both rear wheels are driven evenly</li> <li>• Rear differential is locked</li> <li>• Rear wheels turn at same speed in corners</li> </ul>	<ul style="list-style-type: none"> <li>• More traction compared to 2x4 mode</li> </ul>

### 4x4 - All wheel drive

When to use	Driven wheels	Note
<ul style="list-style-type: none"> <li>• In rough terrain where you expect that 2x4 LOCK drive will not be sufficient.</li> <li>• For driving with loads and in hills</li> <li>• On soft and slippery surfaces</li> <li>• If the rear wheels are slipping</li> <li>• If you need power on all wheels</li> </ul>	<ul style="list-style-type: none"> <li>• All wheels are driven</li> <li>• Front differential is active, rear differential is locked</li> <li>• Rear wheels turn at same speed in corners</li> </ul>	<ul style="list-style-type: none"> <li>• Practically double the traction than in 2x4 LOCK mode</li> <li>• Use this mode only for the necessary time</li> </ul>

### 4x4 - All wheel drive with locked front and rear differential

When to use	Driven wheels	Note
<ul style="list-style-type: none"> <li>• For short-term use in heavy terrain and extreme conditions</li> <li>• When two or more wheels are slipping</li> <li>• When getting the machine out of problems</li> <li>• For driving with loads in hills</li> </ul>	<ul style="list-style-type: none"> <li>• All wheels are driven without differential function</li> <li>• All wheels turn at same speed in corners</li> </ul>	<ul style="list-style-type: none"> <li>• Maximum traction available</li> <li>• ATV can change its handling</li> <li>• Max. speed limit 30 km/h</li> <li>• Use this mode only for the necessary length of time</li> </ul>

**WARNING!**

- Before using the front or rear differential lock, or when changing drive mode from 2x4 to 4x4 and vice versa, stop the vehicle and ride again only after the gears properly engage.
- Driving in 4x4 mode with locked front differential can be dangerous. When driving with locked front differential, reduce your speed and allow for greater maneuvering distances. Locking the front differential can unexpectedly change the handling characteristics of the ATV. Expect a slower turning and respect the changed handling characteristics. If you cannot make a sharp enough turn for the speed you are traveling, you may lose control, which can lead to an accident.
- With locked front differential the maximum speed is limited to 30 km/h.



## Throttle lever

Throttle lever controls engine speed. To increase the engine speed, use your thumb to press the throttle lever; to reduce the engine speed, release the throttle lever. When you release the thumb completely, engine speed returns to idle.

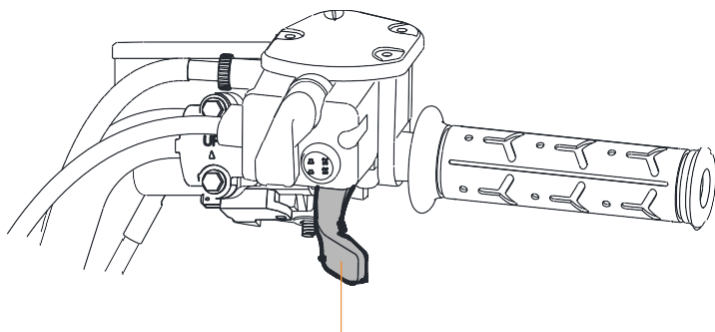

Throttle lever

### **WARNING**

Check whether the throttle lever function is normal before driving. If the throttle lever is stuck or not working properly, it will cause an accident. If the throttle lever is stuck or not working properly, do not start and ride the ATV.

## 12V Accessory outlet / USB Port

Power socket for 12V accessories with rated current less than 10A, and two USB ports are available on this ATV.

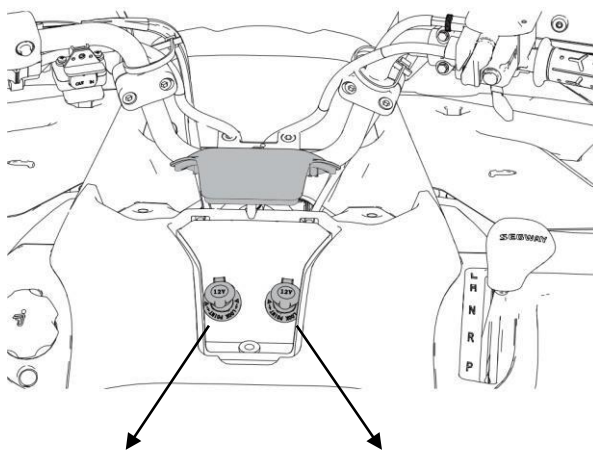

**12V Accessory outlet**

**2x USB port**

Open the accessory outlet cover. Accessory plug and USB ports are active when the ignition key is " ON " .

## Shifting

The shift lever is located to the right of the tank cover. After selecting the gear, wait until the indicator light on the LCD screen confirms that desired gear has really been shifted.

### Shifting scheme

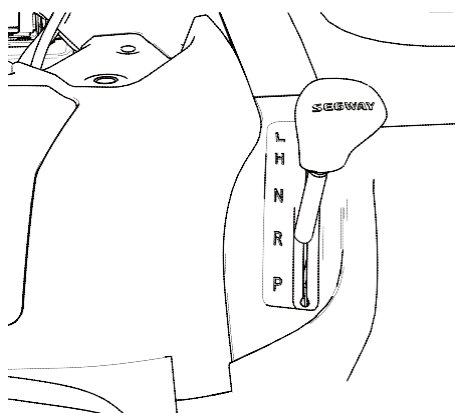

- L** Low speed
- H** High speed
- N** Neutral
- R** Reverse
- P** Parking

### NOTE

You need to step on the brake pedal and stop the vehicle whenever you change the gears.

If you change the gears when the vehicle is moving, it can cause transmission damage.

Place the transmission into Parking gear and lock the Parking brake when you dismount the ATV.

## Parking brake

The parking brake is on the left handlebar.

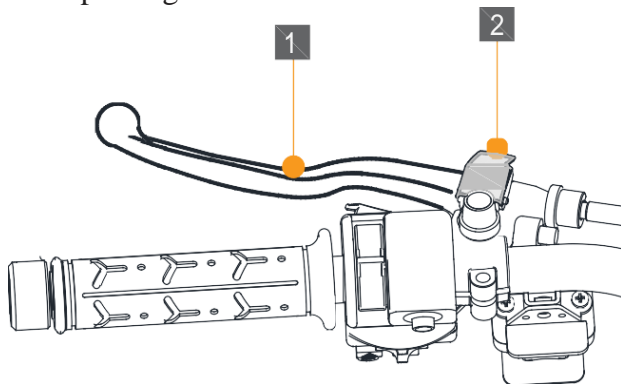

**1** Parking brake lever

**2** Parking brake lock

Using the parking brake:

Place the shifter in "P" and squeeze the parking brake lever and hold;

Press the parking brake lock downward. After hearing the "click" sound, the brake lock gets stuck in the slot.

To release the parking brake:

Squeeze the parking brake lever and the brake lock will automatically spring open. Then release the brake lever and the lock will be released.

## Parking brake lever free play

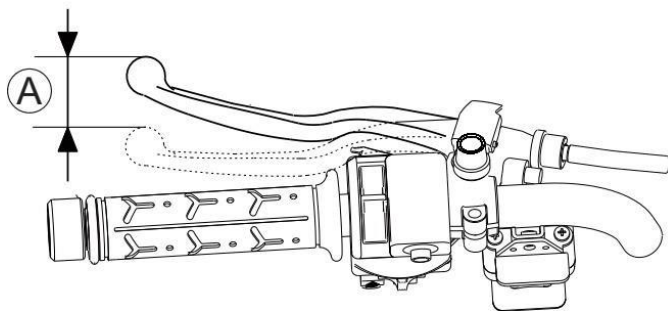

### Parking Brake Check

1. Hold the parking brake lever firmly, squeeze and release it several times. The parking brake lever shall not be stuck.
2. Measure the distance the parking brake lever moves before the brake is engaged. Free play (measured on the brake lever end) shall be: A 25-30mm.
3. Adjust if necessary.

## Foot brake

The foot brake is the main brake system of the vehicle. The foot brake is located on the right floorboard. When you need to slow down or stop, step on the foot brake pedal gradually.

### **Warning:**

**Emergency braking can cause the vehicle to skid or roll over. Do not use emergency braking when not necessary.**

## Foot brake pedal adjustment

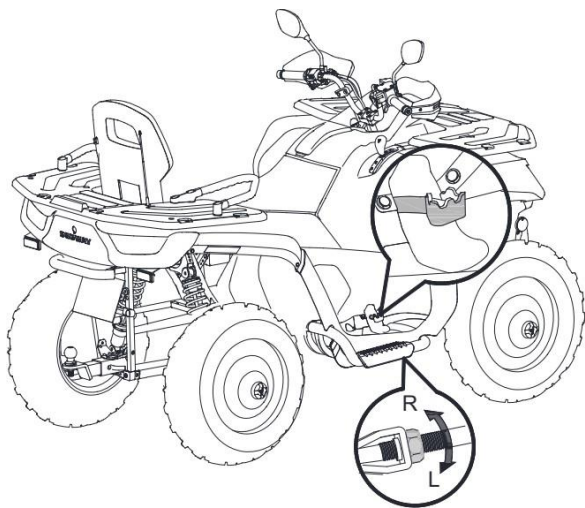

The foot brake lever adjusting nut is located at the bottom, near the foot brake lever. The stroke height of the foot brake lever can be adjusted by turning the foot brake lever nut.

- ◆ Turn nut in direction R to lower the foot brake pedal.
- ◆ Turn nut in direction L to raise the foot brake pedal.

## Front (auxiliary) brake

Front auxiliary braking system is meant as the backup of the main braking system. If the main brake system fails, use the auxiliary brake.

The auxiliary brake is located on your right handlebar. Use the auxiliary brake to brake all wheels. If the rear wheels start to slip when using the auxiliary brake, briefly release the lever and immediately depress it again with reduced force.

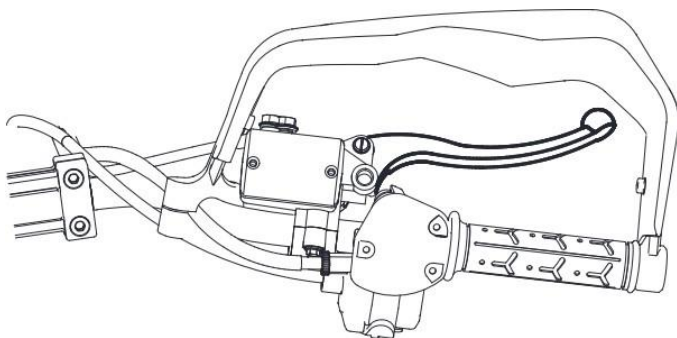

### **▲ WARNING**

Use the auxiliary brake carefully when going downhill. Overuse of the auxiliary brake can cause the vehicle to tip over backwards, resulting in serious injury or death.



## Fuel tank cap

### **⚠ WARNING**

Always use only the fuel type specified for your vehicle. Do not smoke when refueling as you may ignite the fuel and cause fire.

Do not touch other persons or objects with static electricity. This may cause spark to build up and ignite the fuel. Do not let the fuel spill while filling.

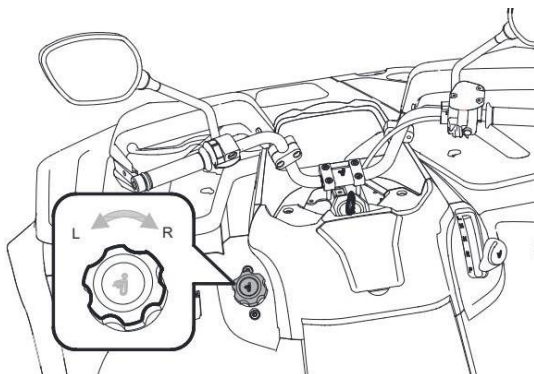

1. Unscrew the fuel tank cap in direction "L";
2. Refuel the vehicle (don't overfill the tank);
3. Tighten the fuel tank cap in direction "R".

## Storage box

This ATV is equipped with three lockers.

### 1 Front storage box

Under the centre of the handlebars, lift the glove compartment cover upwards. The glove compartment is under the cover.

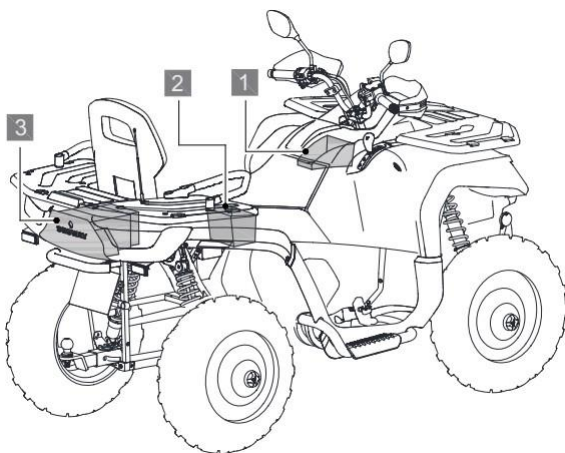

### 2 Underseat storage box

Storage box is under the seat. Seat removal - see Page 118.

### 3 Rear storage box

Located in the rear of the vehicle, this storage box can be locked with the ignition key.

## INSTRUMENT PANEL

Instrument panel provides operator with the actual vehicle information. The driver should understand the meaning of various indicators, warning lights and display information on the instrument panel so as to immediately understand vehicle status.

### NOTE

LCD display may be damaged by using a high pressure washer.





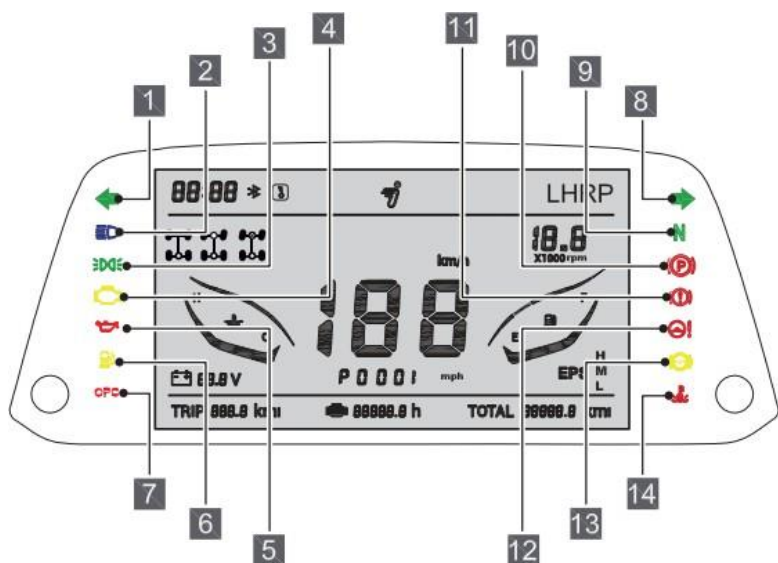

Do not clean the instrument panel with alcohol or corrosive detergents. Corrosive liquids will corrode the surface of the LCD display and cause damage to the instrument panel.





## Indicators / Warning lights

Indicators and warning lights indicate vehicle status. The figure below shows all indicator and warning lights.



## Dashboard indicators / Warning lights



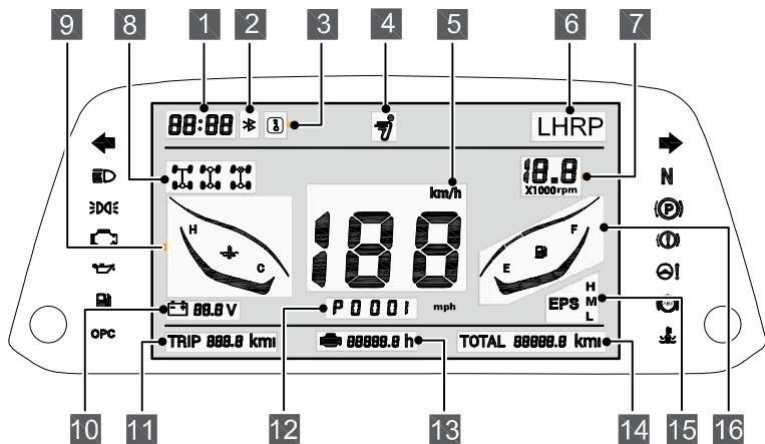

Item	Light	Function
1 Turn Left		This light will illuminate when the left turn signal is turned on.
2 High Beam		This light will illuminate when the headlamp switch is set to High beam.
3 Lights On		Headlights, taillights, license plate light and instrument panel lights are on.
4 Check Engine		This symbol appears if an EFI-related fault occurs. Do not operate the vehicle if this warning appears. Serious engine damage could result.
5 Oil Pressure warning		This symbol appears when oil pressure is too low. Do not operate the vehicle if this warning appears.
6 Fuel level		This symbol indicates that fuel level is too low.
7 Occupant Presence Control	<b>OPC</b>	This indicator displays if the driver has left the seat without parking. Buzzer will sound.
8 Turn Right		This light will illuminate when right turn signal is turned on.
9 Neutral	<b>N</b>	This indicator displays when the transmission is in Neutral.

10 Parking		This light is on when parking brake is applied
11 Brake Warning light		<ul style="list-style-type: none"> <li>• Low brake fluid level</li> <li>• Brake system is faulty</li> </ul>
12 Electric Power Steering warning light		Indicates a failure in EPS system (if equipped)
13 ABS warning light		<p>Indicates failure in any of the following system:</p> <ul style="list-style-type: none"> <li>• ABS (if equipped)</li> <li>• Brake assist system (if equipped)</li> </ul>
14 Coolant temperature warning lamp		Indicator light shows excessive temperature of engine coolant. When this symbol lights up and alarm sounds, the engine should be stopped immediately and shut down. After cooling down to normal temperature, you can continue to ride.

## LCD display



No.	Meaning	Function
1	Clock	Displays actual time
2	Bluetooth	The icon will lit when the Bluetooth is on
3	Remote access	Confirms mobile phone connection for vehicle settings.
4	Segway logo	Logo lights up after power is on.
5	Speed	Displays the actual vehicle speed The speedometer shows speed in MPH (miles) or km/h (km/h).

6	Gear position	<p>Displays the actual gear position</p> <p><b>L</b> - Low speed  <b>H</b> - High speed  <b>R</b> - Reverse  <b>P</b> - Parking</p>
7	RPM	Displays actual engine rpm
8	Drive mode	<p> 2 x 4 mode</p> <p> 2 x 4 lock mode</p> <p> 4 x 4 mode</p> <p> 4 x 4 lock mode</p>
9	Coolant temperature	<p>Displays coolant temperature:</p> <p><b>H</b> - High temperature  <b>C</b> - Low temperature</p>
10	Battery voltage	Displays the actual voltage of the vehicle battery
11	Trip meter	Single trip mileage travelled



12	Diagnostic codes	In case of failure of any of the vehicle's system, fault code is displayed in this area. See p. 68 for diagnostic / fault codes.
13	Engine hours	Displays total engine running time
14	Total mileage	Displays the total mileage the vehicle has traveled
15	EPS Power steering On	EPS mode was set in the APP and the preferred mode was selected: <b>M</b> - Normal mode <b>H</b> - Comfort mode <b>L</b> - Low mode
16	Fuel gauge	Indicates fuel level in the fuel tank. <b>F</b> - Full tank <b>E</b> - Fuel level is low. Refuel.

## Diagnostic Trouble Codes

If electrical components failure or a n y abnormality is detected, this area displays the code information of t h e problem. Please contact your dealer when trouble code appears on your dashboard.

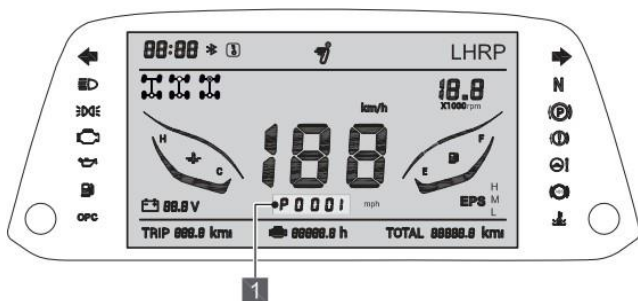

**1** Trouble code display area

System	Failure Code	Failure description
ECU	P0123	Throttle position sensor High Voltage
	P0122	Throttle position sensor Low Voltage
	P0108	Manifold Absolute Pressure/ Barometric Pressure Circuit High
	P0107	Manifold Absolute Pressure/ Barometric Pressure Circuit Low

ECU	P0112	Intake Air Temperature Sensor 1 Circuit High
	P0113	Intake Air Temperature Sensor 1 Circuit Low
	P0117	Engine Coolant Temperature Sensor 1 Circuit High
	P0118	Engine Coolant Temperature Sensor 1 Circuit Low
	P0563	System Voltage High
	P0562	System Voltage Low
	P0560	System Voltage Not plausible
	P0132	O2 Sensor Circuit High Voltage Bank 1 Sensor 1
	P0131	O2 Sensor Circuit Low Voltage Bank 1 Sensor 1
	P0134	O2 Sensor Circuit Bank 1 Sensor 1
	P0130	O2 Sensor Circuit No Activity Detected Bank 1 Sensor 1
	P0032	O2 Sensor Heater Control Circuit High Bank 1 Sensor 1
	P0031	O2 Sensor Heater Control Circuit Low Bank 1 Sensor 1
	P0030	O2 Sensor Heater Control Circuit Bank 1 Sensor 1
	P0262	Cylinder 1 Injector Circuit High
	P0261	Cylinder 1 Injector Circuit Low

ECU	P0201	Injector Circuit/Open - Cylinder 1
	P0629	Fuel Pump “” Control Circuit High
	P0628	Fuel Pump “” Control Circuit Low
	P0627	Fuel Pump “” Control Circuit /Open
	P0650	MIL Control Circuit Low
	P0650	MIL Control Circuit Open
	P0650	MIL Control Circuit Not plausible
	P0692	Fan 1 Control Circuit High
	P0691	Fan 1 Control Circuit Low
	P0480	Fan 1 Control Circuit
	P0322	Ign./Distributor Eng.Speed Inp.Circ. No Signal
	P0459	Evaporative Emission System Purge Control Valve Circuit High
	P0458	Evaporative Emission System Purge Control Valve Circuit Low
	P0444	Evaporative Emission System Purge Control Valve Circuit Open
	P1116	Engine Coolant Temp High
P0501	Vehicle Speed Sensor “A” Range/ Performance	

<b>EPS</b>	E0001	No midpoint of torque is written
	E0002	No end point of rotor angle is written
	E0003	Memory read write failure
	E0004	The main torque sensor is disconnected
	E0005	Abnormal output of main torque sensor
	E0006	The secondary torque sensor is disconnected
	E0007	Abnormal output of secondary torque sensor
	E0008	The difference between main and secondary torques is too large
	E0009	The difference between the main torque before and after amplification is too large
	E0010	Electrical machinery unassisted
	E0011	Over electric current
	E0012	Abnormal busbar electric current
	E0013	CAN communication abnormal (Output abnormal)
	E0014	Rotor Angle jump
	E0015	The rotor Angle sensor is disconnected
	E0016	Power module failure
	E0017	Abnormal A phase electric current

<b>EPS</b>	E0018	Abnormal C phase electric current
	E0019	Steering wheel Angle small gear abnormal
	E0020	Steering wheel Angle middle gear abnormal
	E0021	Steering wheel Angle jumps
	E0022	Steering wheel Angle value exceeds limit
	E0023	The steering wheel Angle is not right
	E0024	Abnormal voltage at electrical machinery end
<b>T-BOX</b>	T0001	GPS module failure
	T0002	4G module failure
	T0003	Bluetooth module failure
	T0004	Sensor failure
	T0005	Power CAN failure
	T0006	Body CAN failure
<b>ABS</b>	A0001	Left front wheel speed error signal
	A0002	Right front wheel speed error signal
	A0003	Left rear wheel speed error signal
	A0004	Right rear wheel speed error signal
	A0005	Voltage of ABS module is too high

<b>ABS</b>	A0006	Voltage of ABS module is too low
	A0007	Vehicle speed single failure
	A0008	CAN single failure

## Display setting

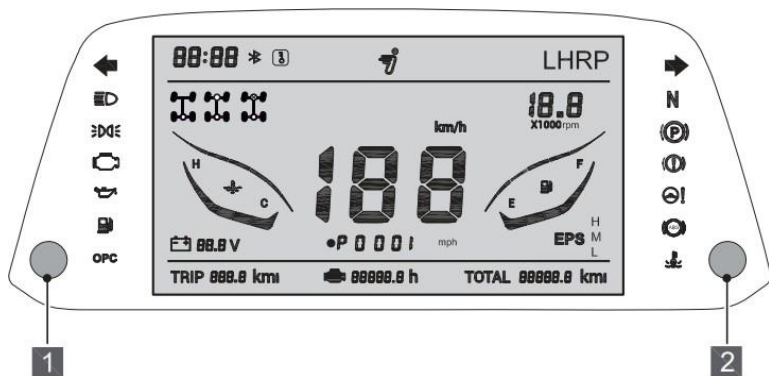

**1** MODE

**2** SELECT

### MODE button

Press "MODE" button: Set LCD display brightness in 5 steps, from dark to bright.

Press "SELECT" button: Change the units (MPH or KPH);  
Press and hold "SELECT" key: Reset the single trip mileage;

Press and hold "MODE" and "SELECT" at the same time:  
Clock setting; the hour digit blinks at first, press "SELECT"  
to adjust the hours, then press "MODE" to adjust the  
minutes, finally press "MODE" key to Save and Exit;



# HANDLEBARS ADJUSTMENT

The handlebars can be adjusted to suit your needs.

## WARNING

Improper adjustment of the handlebars or improper torque of tightening bolts can result in limited steering or loose handlebars; loss of control can result in severe injury or death. Always follow correct adjustment procedure, or visit Segway Powersports Authorised service.

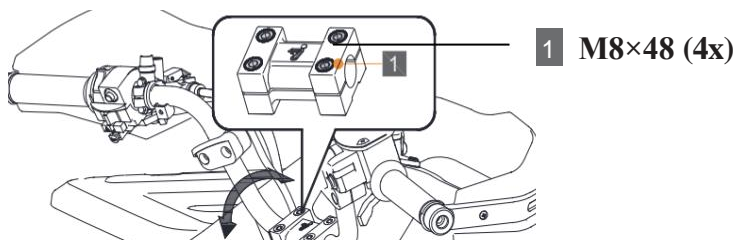

### Handlebar bolts tightening torque: 35 Nm

1. Loosen the four handlebar bolts.
2. Adjust the handlebars position according to your preferences.
3. Tighten the two front bolts, then tighten the two rear bolts. Leave a gap of 3 mm at the back of the clamp block.
4. Tighten all screws and check that handlebars do not restrict the steering.

# OPERATION

<b>BASIC DRIVING GUIDE...</b>	<b>77</b>
Trail etiquette .....	77
Know your riding area .....	78
Break-in period.....	78
Burnishing Brake Pads .....	78
CVT clutch / Drive belt .....	79
Mounting the ATV.....	79
Starting the engine.....	80
Parking.....	80
Turns .....	80
Riding in reverse.....	81
Turning around on a hill (k-turns) .....	82
Riding on slippery surfaces .....	83
Riding through water.....	84
Crossing obstacles .....	85
Riding uphill .....	86
Riding downhill .....	88
Driving on a sidehill / Traversing .....	89

# OPERATION

Parking on an incline .....	90
Braking.....	91
Parking the vehicle.....	91
Break-in.....	92
<b>PRE-RIDE INSPECTION... ..</b>	<b>93</b>
Pre-ride checklist... ..	93
<b>LOAD LIMITS &amp; GUIDELINES .....</b>	<b>95</b>
Maximum loading capacities .....	97
Loading Guidelines... ..	98
Trailer.....	99
<b>WINCH GUIDE.....</b>	<b>101</b>

This section provides you with basic operating instructions including how to start and stop the vehicle, driving skills and precautions when driving on different terrains.

Even if you've ridden other ATVs, you must take time to familiarize yourself with how this ATV handles. Practice in flat wide open area until you are familiar with this model.

### **WARNING**

Failure to inspect that your vehicle is in safe operating condition before ride increases the risk of an accident. Always perform Pre-Ride Inspection as described in this manual before every ride to make sure your vehicle in safe operating condition. Always follow the inspection and maintenance procedures and schedules described in this manual. See also the Periodic Maintenance section.

## **BASIC DRIVING GUIDE**

### **Trail etiquette**

Always practice good etiquette when riding. Allow a safe distance between your vehicle and other vehicles operating in the same area. Communicate to oncoming riders by signaling the number of vehicles in your group. When stopping, park your vehicle at the edge of the trail as far as possible to allow others to pass safely.

## Know your riding area

Familiarize yourself with all laws and regulations concerning the operation of this vehicle in your area. Respect the environment in which you ride your vehicle.

Find out where the designated riding areas are by contacting your dealer, a local riding club, or local officials.

## Break-in period

Break-in period is the first 300 km of operation. Careful break-in of new engine and drivetrain components will improve the performance and service life of your ATV. Follow these steps carefully. After break-in, change the engine oil and oil filter.

## Burnishing brake pads

To achieve full braking performance, the brakes need about 200 km of running-in.

Heavy or excessive braking when brake system is new may damage your pads and brake discs.

## CVT clutch / Drive belt

Proper break-in of the C V T clutch and drive belt will ensure longer life and better performance. Break-in the clutch and drive belt at low speeds for the recommended period, with pulling only light loads. Avoid violent acceleration and high-speeds during break-in period. If the drive belt is broken, be sure to clean also the intake and outlet ducts. Take out any debris from the clutch and engine compartment when belt is replaced.

## Mounting the ATV

1. Wear protective riding gear. See the Safe Riding Gearsection.
2. Perform the pre-ride inspection.
3. Place the transmission in Park.
4. Mount the vehicle from the left side.
5. Sit upright with both feet on the footrests and both hands on the handlebars.
6. Start the engine and allow it to warm up.
7. Drive slowly. Practice maneuvering and using the throttle and brakes on flat surfaces.

## Starting the engine

1. Apply forcefully the foot brake.
2. Turn the ignition key to the "ON" position (P. 38).
3. Press the start button (green) to start the engine; (P. 39)
4. Allow the engine to warm up.

## Parking

1. Apply the foot brake and set the shift lever to the "P" position;
2. Press the engine stop button (red) to stop the engine; (P. 39)
3. Turn the key to the "OFF" position (P. 38); the key can be taken out of the main switch.
4. Lock the Parking brake lever; (P. 53)

## Turns

Turning on ATV involves moving your body. You must learn to lean and shift body weight into turns to maintain control.

1. Slow down.
2. Steer in the direction of the turn.
3. Keep both feet on the footrests.
4. Lean your upper body to the inside of the turn while supporting your weight on the outer footrest. This technique alters the balance of

traction between the rear wheels, allowing the turn to be made smoothly. The same leaning technique should be used for turning in reverse.

5. Practice turns at slow speeds before attempting to turn at faster speeds.

### **WARNING**

Turning improperly can result in vehicle overturn. Never turn abruptly or at sharp angles. Never turn at high speeds. Never turn quickly when carrying cargo.

## Riding in reverse

If you need to reverse, make sure the area behind you is clear, and operate at low speed.

Do not use the Override switch unless additional wheel speed is required for vehicle movement. Use the Override button with caution as it greatly increase rearward speed. Do not operate at wide open throttle. Operate the throttle just enough to maintain a desired momentum.

To reverse, follow the following procedure :

1. Always check for obstacles or people behind you; be sure there are no obstacles or people in your way.
2. Press brake pedal and change the gears to "R" ;



## Turning around on a hill (k-turns)

If the engine stalls while riding uphill, or if wheels start to spin, never back down the hill! Use the k-turn instead to turn your ATV around from the hill.

1. Stop and lock the parking brake while keeping your body weight shifted forward.
2. The machine allows engine braking when driving downhill.
3. Leave the transmission in gear and stop the engine.
4. Dismount the vehicle on the uphill side, or on the left if the vehicle is pointing straight uphill. While staying uphill of the vehicle, turn the handlebars fully to the left.
5. While holding the brake lever, release the parking brake lock and slowly allow the vehicle to roll around to your right until it's pointing across the hill or slightly downward.
6. Lock the parking brake. Remount the vehicle from the uphill side, keeping your body weight uphill.
7. Keep the transmission in gear and start the engine.
8. Release the parking brake and proceed slowly, controlling speed with the brake lever until you get on more level surface.

## Riding on slippery surfaces

Whenever riding on slippery surfaces such as wet trails or loose gravel, or during freezing weather, follow these precautions:

1. Do not operate on excessively rough, slippery or loose terrain.
2. Slow down when entering slippery areas.
3. Engage 4x4 drive before wheels begin to lose traction.

### NOTE

Severe damage to drivetrain may occur if the 4x4 is engaged while the wheels are turning. Allow the rear wheels to stop before engaging 4x4, or engage 4x4 before wheels begin to lose traction.

4. Maintain high level of alertness, reading the trail and avoiding quick turns which can cause slides.
5. Never apply the brakes during the slide. Correct the slide by turning the handlebars in the direction of the slide.

## Riding through water

This ATV can operate through water with a maximum recommended depth up to the footrests. Follow these procedures when operating through water:



### CAUTION

Serious engine damage can result if the vehicle is not thoroughly inspected after operation in water. Perform the services outlined in the Periodic Maintenance Chart. Following areas need special attention: engine oil, transmission oil and all grease fittings. If the vehicle tips or overturns in water, or if the engine stops during or after operating in water, service is required before restarting the engine. Contact Segway Powersports Authorised service. If it's impossible to bring the vehicle in before starting the engine, perform the service outlined in the Vehicle Immersion section of this manual, and take the vehicle in for service at the first opportunity.

1. Determine water depth and current before entering the water.
2. Choose a crossing where both banks have gradual inclines.
3. Avoid operating through deep or fast-flowing water.
4. After leaving the water, test the brakes. Apply them lightly several times while driving slowly. The friction will help dry out the pads.

If it's unavoidable to enter water deeper than to the footrests:

- ◆ Proceed slowly. Avoid rocks and obstacles.
- ◆ Balance your weight. Avoid sudden movements.
- ◆ Maintain steady speed. Do not make sudden turns or stops. Do not make sudden throttle changes.

## Crossing obstacles



Follow these precautions when crossing obstacles:

1. Before operating in a new area, check for obstacles.
2. Watch out for bumps, potholes and other obstacles in the terrain.
3. When you approach the obstacle, reduce your speed, be prepared to stop.
4. Never try to ride over large obstacles such as large rocks or fallen logs.
5. Always have a passenger dismount when you approach the obstacle that could cause a fall from the vehicle, or tip over.

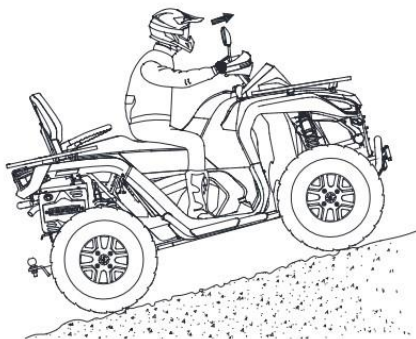

## Riding uphill

Braking and handling are greatly affected when operating in hilly terrain. Improper procedure can cause loss of control and rollover.

Whenever riding uphill, follow this method:

1. Always shift to 4x4 mode before ascending or descending a hill. Never ride in TURF mode (2x2 without differential lock) when operating on a hill or other irregular terrain.
2. Drive straight uphill.
3. Avoid steep hills. Maximum incline is:
  - ◆ AT6S : 25°
  - ◆ AT6L : 15°
4. Always check the terrain carefully before ascending any hill.
5. Never climb hills with excessively slippery or loose surfaces.
6. Keep both feet on the footrests.
7. Lean as far forward as possible. A passenger should also shift his / her body weight uphill.
8. Proceed at a steady pace and steady throttle. Suddenly opening the throttle can cause the ATV to flip over backwards.

## Riding downhill

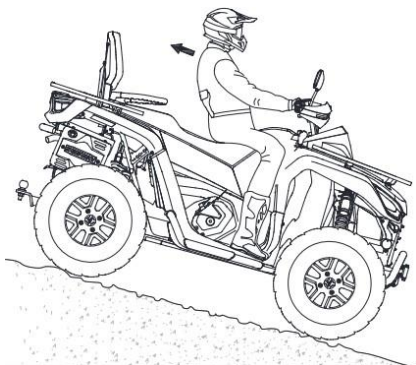

When driving downhill, follow these precautions:

1. Never operate in TURF mode while riding downhill or other irregular terrain.
2. Avoid steep hills.

**Never operate up or down hills steeper than:**

- ◆ AT6 S : 25°
  - ◆ AT6 L : 15°
3. Always check the terrain carefully before descending a hill.
  4. Always descend a hill with the transmission in gear. Do not descend a hill with the transmission in neutral.

5. Slow down. Never go down a hill at high speed.
6. Steer straight downhill. Avoid descending a hill at an angle, this would cause the vehicle to lean sharply to one side.
7. Lean as far backward as possible. A passenger should also shift his / her body weight uphill.
8. Apply the brakes slightly. Applying the brakes too much may cause the rear wheels to lock, which could result in loss of control.

## Driving on a sidehill / Traversing



Driving on a sidehill is not recommended. Improper procedure could cause loss of control or overturn. Avoid sidehilling unless absolutely necessary.



**If sidehilling is unavoidable, follow this method:**

1. Slow down.
2. Avoid crossing the side of a steep hill.
3. Lean into the hill, transferring your body weight toward the hill while keeping your feet on the footrests.
4. If the vehicle begins to tip, quickly turn the handlebar downhill, if possible, or get off on the uphill side immediately!

**Parking on an incline**

**Avoid parking on an incline if possible. If it's unavoidable, follow this method:**

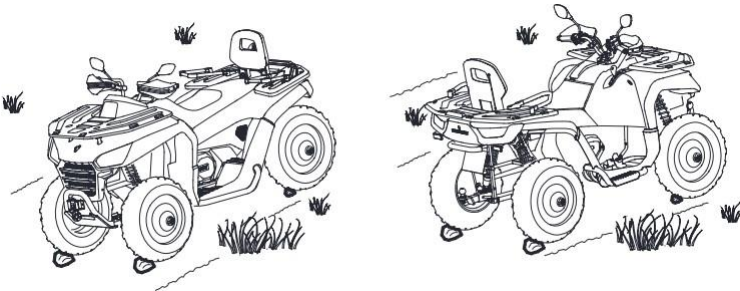

1. Stop the engine.
2. Place the transmission in Park.
3. Lock the Parking brake.
4. Always block the rear wheels on the downhill side.

## Braking



1. Release the throttle lever completely. (When the throttle lever is released completely and engine speed slows to idle, the vehicle has no engine braking.)
2. Press the brake pedal evenly and firmly. Practice starting and stopping using the brakes, until you're familiar with the controls.

## Parking the vehicle

1. Stop the vehicle on a level surface. When parking inside a garage or other structure, be sure that area is well ventilated and that the vehicle is not close to any source of flame or sparks, including appliances with pilot lights.

2. Place the transmission in Park.
3. Turn the engine off.
4. Engage the Parking brake.
5. Slowly release the brake pedal and make sure the transmission is in Park before exiting the vehicle.
6. Remove the ignition key to prevent unauthorized use.

## Break-in

The engine needs 300 km break-in period.

During break-in:

- ◆ Avoid using full throttle.
- ◆ Always use less than 3/4 throttle.
- ◆ Do not pull or carry heavy loads.
- ◆ Avoid hard or continuous acceleration.
- ◆ Vary the engine RPM

The brakes need a 200km run-in period.

New brakes will not operate at their maximum efficiency until the run-in period is over. Brake performance may be compromised, so be careful.

### NOTE

During this period, avoid full-throttle operation, rapid acceleration, and riding in constant RPM.

## PRE-RIDE INSPECTION

Perform a pre-ride inspection before every ride to detect any potential problem that could occur during operation. The pre-ride inspection can help you monitor component wear and deterioration before they become a problem.

Correct any problem that you discover to reduce the risk of a breakdown or crash.

### Pre-Ride Checklist

Item	Remarks	Page
Brake system / pedal stroke	Check correct operation	P56-58
Brake fluid	Check level	P133~ P135
Auxiliary brake	Check operation	P58
Front suspension	Check, lubricate if necessary	P145
Rear suspension	Check, lubricate if necessary	P145
Tires	Check condition and air pressure	P137

Wheels	Check bolts / nuts for proper torque	P139
Fuel	Check level	P30
Coolant	Check level	P131
Indicator lights	Check	P63
Switches	Check operation	P38
Ignition switch	Check operation	P39
Headlights	Check operation	P41
Brake light /taillight	Check operation	
Riding equipment	Wear approved helmets, care and protective clothing	P25
Trailer hitch (optional equipment)	Check cables and connector	P100

## HAULING CARGO & LOAD LIMITS

Front and rear racks are capable of carrying goods up to specified capacity. Tow hitch behind the vehicle can tow trailers and accessories.

Loads carried by the vehicle will affect the vehicle's operation, stability and braking distance. Do not exceed the vehicle load limit, including driver, passenger, cargo, accessories and tongue weight. Unsecured loads can create unstable operating conditions, which could result in loss of control of the vehicle.

### **WARNING**

- ◆ Strictly follow instructions in the operator's manual of the mounted or towed machinery or trailer. Do not operate the tractor-machine or tractor-trailer combination unless all instructions have been followed.
- ◆ Stay clear of the area between vehicle and trailer.
- ◆ Reduce speed and allow greater braking distance when carrying loads.
- ◆ Carry loads as low on the racks as possible. Too much cargo on the racks can raise the vehicle's center of gravity and reduce stability.

 **WARNING**

- ◆ Fix all loads before operation. Unstable load can create unstable driving conditions, which can result the vehicle to lose control.
- ◆ Heavy loading causes braking and control problems. Take extra care when using the brakes of a loaded vehicle. Avoid terrain or conditions that may result in backing downhill.
- ◆ Take extra care when riding with load beyond the edges of the rack. Stability and maneuverability may be adversely affected, causing the vehicle to tip over.
- ◆ Do not block the headlight beam when loading the front rack.
- ◆ Don't drive faster than in recommended speeds. When towing loads on flat ground, the vehicle should not exceed 15 km/h. When towing loads over rough terrain, turning, climbing or descending a hill, you must not exceed speeds of 8 km/h.

## Maximum loading capacities

Never exceed maximum loading capacities!

	AT6 S	AT6 L
Front Rack	40 kg	40 kg
Rear Rack	60 kg	60 kg
Towing capacity	1028 kg (off-road)	

### Note:

Load capacity and towing capacity may vary according to your model / version. For actual values please refer to the technical certificate of your vehicle.



## Loading guidelines

### **When transporting cargo, please follow these instructions:**

1. Do not exceed the weight capacities specified on the warning labels and in this manual.
2. Never ride with a passenger on the front or rear rack.
3. Cargo weight distribution should be 1/3 on the front rack and 2/3 on the rear rack.
4. Make sure that the cargo is firmly secured to the rack before driving.
5. Avoid riding on steep slopes when carrying cargo or pulling a trailer.
6. Use low-speed gear when hauling heavy cargo.
7. When hauling or towing cargo, operate the vehicle with great caution.

## Trailer

If you need to tow a trailer, please be aware that the vehicle's tow weight capacity does not include weight of the tow hitch.

- ◆ The combination of the weight on the rear rack and weight of the tow hitch shall not exceed loading capacity of the rear rack.
- ◆ The total load (weight of the operator, passenger, accessories, cargo and trailer) shall not exceed the maximum capacity of the vehicle.

### **If a designated attachment point is provided on the tow hitch:**

Either:

Pass the cable through the attachment point and clip it back on itself.

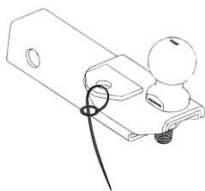

Or:

Attach the clip directly to the attachment point. This alternative must be specifically permitted by the trailer manufacturer since the clip may not be strong enough for use in this way.

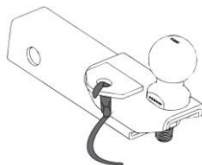

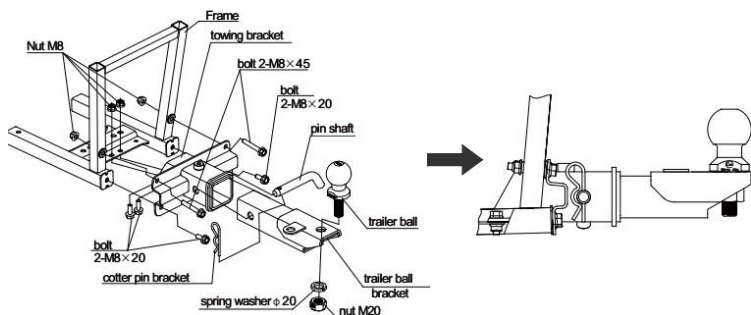

## NOTE

The speed must be less than 15 km/h when towing.

Use of improper hitch or exceeding the maximum tongue weight capacity may cause serious damage to your vehicle. In this case, your ATV will not be covered by warranty. Never install car accessories on this ATV. Always install only accessories approved or designed for ATV use.

## WINCH GUIDE

If your model is equipped with a winch, please read this guide before use to understand and to familiarize yourself with safety precautions and operating instructions.

### **WARNING**

The user must read and understand the operating instructions and warnings of this operation manual. If the instructions or warnings are not followed, serious property damage or personal injury may occur.

- ◆ It is strictly prohibited for people under 16 years to operate this winch.
- ◆ Before and during operation, pay attention to the safety and environmental conditions within the operating range of the winch
- ◆ Do not overload the winch. Ensure that all winch accessories meet or exceed working load limit of the cable. We recommend using an optional pulley block and double rope winching to reduce the load on the winch, cable and battery. When using double rope winching, the rated value of the pulley block should be 2x the pulling capacity of the winch.
- ◆ Do not try to pull heavy loads for a long period of time. Electric winches are only designed for limited time use, winch should not be used under constant

load. Do not pull for more than 1 minute, or near to maximum rated load. If the winch motor gets very hot, stop winching and let it cool down for a few minutes.

- ◆ Always be sure that at least five (5) full turns of winch cable are wrapped around the winch drum.
- ◆ Avoid pulling from extreme angles, as this will cause the winch cable to accumulate at one end of the drum and damage the cable.
- ◆ Be aware, that the maximum pulling capacity of the winch is the maximum pulling capacity on the first layer only - only the first layer can be pulled in max. winch capacity. Do not overload the winch.
- ◆ Never hook the cable back to itself; otherwise the cable will be damaged. Use trunk protection protector.
- ◆ Before operation, make sure that the winch is firmly fixed to the vehicle or bracket.
- ◆ Before moving heavy objects, check the winch cable to prevent kinks and uneven wire layers. The slacked cable must be properly tightened under a weight of about 50 kg.
- ◆ When pulling the load, be sure to lay a blanket or protective cloth on the cable near the hook end. This will prevent the possibility of breaking the wire cable and help prevent serious injuries and damage.

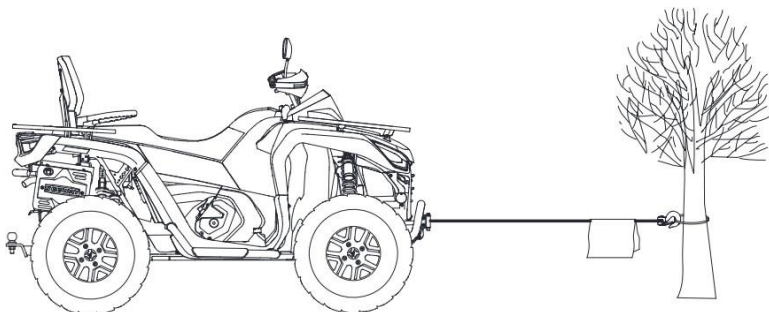

- ◆ Pay attention to the dangerous area. Stay away from the dangerous area during the operation. The dangerous area is the area of winch drum, fairlead, winch cable, pulley block, hook and motor.
- ◆ When the winch is under load, do not approach or cross the cable.
- ◆ When using the winch to move the load, place the vehicle transmission in neutral, apply park brake and plug all wheels with chocks. When the winch is in use, the vehicle engine should be started to fully charge the battery. Never use the winch with insufficient battery voltage.
- ◆ Never disconnect the power supply when there is

a load on the winch.

- ◆ After the winching, release the load immediately. Do not tighten the cable.
- ◆ Always stay away from cable, hook and winch.
- ◆ Check winch, cables, hook, and broken strands of worn wires regularly. When operating with the steel wire cable, wear thick leather gloves. Never let the steel wire cable run through your hands. Check the steel cable before use. Crushed, pinched, worn or kinked areas seriously reduce cable working load limit. Damaged wire cable should be replaced.
- ◆ The clutch should be disconnected first, and then the winch cable should be pulled by the hook of the protective lever.
- ◆ Always use the hook strap when handling the hook.
- ◆ After the use, pull the winch cable tightly with about 50 kg of tension, using the hook strap.
- ◆ Do not operate the winch under the influence of alcohol or drugs.
- ◆ If there is a problem, cut off the battery immediately and check carefully.

- ◆ Wear goggles, long sleeves, non-slip boots, work cap, thick leather gloves. Keep your hair under the work cap and remove all personal jewelry.
- ◆ Do not repair or modify any part of the winch.
- ◆ When the winch is in use, be sure to start the vehicle engine and set the gear position to "N" to make sure battery is charged;
- ◆ When the winch is working, the current is large. You must start the engine and apply throttle lightly to avoid damage to the battery;
- ◆ Winch cable and pulled vehicle should be in a straight line. Too big an angle will change the direction of the pulling force and damage the cable;
- ◆ If severe noise or vibration occurs during winching, stop the winch immediately.



**▲ WARNING**

When releasing or retrieving the winch cable, both ends of the cable must be left with sufficient length to prevent the cable from being over-rolled in or out. When the cable is retrieving, please maintain a certain tension (cca 50 kg) so that the cable can be retracted smoothly and can be wound tightly during retrieving.

**▲ WARNING**

Always use the strap to pull the hook. Do not hold the hook with your hands. This is not only important when winding the wire rope, but also when removing the wire rope from the winch under power.



# MAINTENANCE

<b>REGULAR MAINTENANCE .....</b>	<b>111</b>
<b>PERIODIC MAINTENANCE TABLE.....</b>	<b>112</b>
<b>LUBRICATING GUIDE .....</b>	<b>117</b>
<b>SEAT REMOVAL .....</b>	<b>118</b>
<b>TANK COVER... ..</b>	<b>119</b>
<b>FRONT MAINTENANCE PANEL REMOVAL</b>	<b>120</b>
<b>INSTRUMENT COVER REMOVAL.....</b>	<b>121</b>
<b>ENGINE OIL.....</b>	<b>122</b>
Oil recommendation... ..	123
Engine oil level check .....	124
Changing engine oil and filter .....	126
Front / Rear Differential oil and Final Drive oil	127
<b>COOLANT .....</b>	<b>129</b>
Adding Coolant .....	129
<b>BRAKE SYSTEM .....</b>	<b>131</b>
Brake fluid .....	132

# MAINTENANCE

Front brake fluid.....	134
Brake pad inspection.....	135
<b>TIRES.....</b>	<b>136</b>
Tire pressure .....	136
Tire tread depth.....	137
When to Change a tire.....	138
Wheels removal.....	138
Tire replacement.....	140
<b>SHOCKABSORBERS ADJUSTMENT... ..</b>	<b>141</b>
Oil shock absorber.....	141
Adjustable shock absorber.....	142
<b>SUSPENSION LUBRICATION... ..</b>	<b>144</b>
<b>FRONT AND REAR AXLE BOOTS .....</b>	<b>145</b>
<b>AIR FILTER .....</b>	<b>146</b>
<b>LIGHTS.....</b>	<b>148</b>
Headlamps replacement .....	149
Taillight / rear turn light replacement.....	151
High beam adjustment .....	152
<b>SPARK PLUG.....</b>	<b>155</b>
Spark plug inspection.....	156

# MAINTENANCE

<b>SPARK ARRESTOR.....</b>	<b>158</b>
<b>BATTERY .....</b>	<b>160</b>
Battery removal.....	161
Battery charging.....	162
Battery installation .....	163
Jump-starting .....	164
<b>FUSES .....</b>	<b>165</b>
Fuse box... ..	166
Fuse/relay ratings and location .....	167
Fuse replacement... ..	170
<b>APPEARANCE CARE.....</b>	<b>171</b>
Cleaning the vehicle .....	172
Cleaning tips.....	172
Vehicle storage.....	172

**WARNING**

Failure to perform maintenance instructions and precautions correctly can result in serious injury or death. Please follow the steps and precautions in this manual.

Proper maintenance is essential for safe operation of this vehicle. To help you properly maintain your vehicle, this part of this manual provides a maintenance plan.

Maintenance schedule intervals assume the vehicle is operated under normal conditions. If your vehicle often drives on rough roads or environments, it may require additional and more frequent maintenance. If you have some mechanical knowledge and basic tools, many maintenance items can be completed by yourself. However, we suggest to ask for certain maintenance a Segway Powersports service. Some maintenance may require special tools and professional skills. These tasks are best done by authorized Segway Powersports services. Even if you have extensive self-maintenance experience, we still recommend carrying out repairs and maintenance by authorized Segway Powersports service.

## REGULAR MAINTENANCE

Any qualified repair shop can maintain, replace or repair the emission control device or system on your vehicle. Authorized Segway Powersports dealers can perform any services that may be required for your vehicle.

If any part, provided by an after-sales component manufacturer, reduces the effectiveness of vehicle emission controls, it is a potential violation of the Clean Air Act.

The user is responsible for performing the regular maintenance specified in this manual. Careful regular maintenance will help keep your vehicle in safe and reliable condition. Check, clean, lubricate, adjust and replace parts when necessary. When the inspection shows that the parts need to be replaced, new parts are available from the dealer.

If you are not familiar with safe service and adjustment procedures, qualified dealers can perform these operations. The maintenance intervals in the chart below are based on average riding conditions. Frequently used vehicle must be checked and repaired more frequently.

## PERIODIC MAINTENANCE CHART

Careful periodic maintenance will help keep your vehicle in the safest, most reliable condition. Inspection, adjustment and lubrication of important components are explained in the periodic maintenance chart.

Inspect, clean, lubricate, adjust and replace parts as necessary. When inspection reveals the need for replacement parts, use genuine parts available from your authorized dealer. Service and adjustments are important for proper vehicle operation. If you're not familiar with safe service and adjustment procedures, have a qualified dealer perform these operations.

Maintenance intervals in the following chart are based upon average riding conditions. Vehicles subjected to severe use must be inspected and serviced more frequently.

### ***Severe use is defined as:***

- ◆ **Frequent riding in mud, water, or sand**
- ◆ **Frequent or prolonged operation in dusty environments**
- ◆ **Short trips in cold weather**
- ◆ **Racing or racing-style with high RPM use**
- ◆ **Prolonged low speed, heavy load operation**
- ◆ **Extended idle**

## MAINTENANCE CHART KEY

SYMBOL	DESCRIPTION
▶	Perform these procedures more often for vehicles subjected to severe use.
D	Have an authorized dealer perform these services.

**▲ WARNING**

Improperly performing the procedures marked with a **D** could result in component failure and lead to serious injury or death. Have an authorized dealer perform these services.



Perform all services at whichever maintenance interval comes first.

ITEM	MAINTENANCE INTERVAL (WHICHEVER COMES FIRST)			REMARKS
	HOURS	CALENDAR	KM	
Steering		Pre-Ride		Visually inspect, test, or check components. Make adjustments and/or schedule repairs when required
Front suspension		Pre-Ride		
Rear suspension		Pre-Ride		
Tires/ Wheels/ fasteners		Pre-Ride		
Brake fluid level		Pre-Ride		
Brake system		Pre-Ride		
Throttle lever		Pre-Ride		
Engine oil level		Pre-Ride		
Coolant		Daily		Check level
Power steering unit (if equipped)		Daily		Inspect daily
Lighting (Headlight/ taillight ...)		Daily		Check operation; apply dielectric grease if replacing lamps
▶ Air filter element		Weekly		Inspect; replace as needed

ITEM		MAINTENANCE INTERVAL (WHICHEVER COMES FIRST)			REMARKS
		HOURS	CALENDAR	KM	
▶ D	Brake pad wear	10 H	Monthly	160	Inspect periodically
	Battery	20 H	Monthly	320	Check terminals; clean; test
	Fuel System	20 H	Monthly		Inspect; cycle key to pressurize fuel pump; check lines and fittings for leaks and abrasion
▶	Engine oil change	25 H	1 M	320	Break-in oil and filter change
▶	Front gearcase oil	25 H	1 M	320	Break-in oil level check
▶	Rear gearcase oil	25 H	1 M	320	Break-in oil level check
▶	General lubrication	50 H	3 M	800	Lubricate all fittings, pivots, cables, etc.
	Throttle Body Intake Duct	50 H	6 M		Inspect duct for proper sealing/air leaks
	Drive belt	50 H	6 M	800	Inspect; adjust; replace as needed
	Cooling system	50 H	6 M	1600	Inspect coolant strength seasonally; pressure test system yearly
▶	Engine oil change	100 H	6 M	1600	Change the oil and filter
▶	Oil lines and fasteners	100 H	6 M	1600	Inspect for leaks and loose fittings
▶	Front gearcase oil	100 H	12 M	1600	Change oil;
▶	Rear gearcase oil	100 H	12 M	1600	Change oil
D	Fuel system/filter	100 H	12 M	1600	Cycle ignition key to pressurize fuel pump; check for leaks at fuel cap, fuel lines/rail and fuel pump; replace lines every two years

ITEM		MAINTENANCE INTERVAL (WHICHEVER COMES FIRST)			REMARKS
		HOURS	CALENDAR	KM	
▶	Radiator	100 H	12 M	1600	Inspect; clean fins / external surfaces
▶	Cooling hoses	100 H	12 M	1600	Inspect for leaks
▶	Engine mounts	100 H	12 M	1600	Inspect
	Exhaust muffler/ pipe / Joints	100 H	12 M	1600	Inspect; clean; replace worn parts
D	Spark plug	100 H	12 M	1600	Inspect; replace as needed
D	Clutches (drive and driven)	100 H	12 M	1600	Inspect; clean; replace worn parts
D	Front wheel bearings	100 H	12 M	1000	Inspect; replace as needed
D	Brake fluid	200 H	24 M	2000	Change every two years
	Spark arrester	300 H	36 M	3000	Clean out
▶	Coolant		60 M		Replace coolant
D	Valve clearance	500 H		5000	Inspect; adjust
D	Toe adjustment				Inspect periodically; adjust when parts are replaced
	Headlight aim				Adjust as needed

## LUBRICATING GUIDE

Check and lubricate all components at the intervals listed in the periodic maintenance chart. Items not listed in the chart should be lubricated in the general lubrication interval. The rocker arm is lubricated at the factory and does not require additional lubrication. However, if these components are heavily used, the user may perform additional lubrication as required.

Item	Recommended lubricant	Capacity	Procedure
Engine oil	MAXIMA 10W-40	2.4L	Maintain level in safe range on dipstick
Front axle gear oil	SAE 75W/90 GL-5	150ml	Change every 2000 km
Rear axle gear oil	SAE80W/90 GL-5/ SAE75W/90 GL-5	240ml	
Coolant			Maintain the level between the fill lines.
Brake fluid	DOT4/DOT3		Maintain the level between the fill lines.
Suspension, stabilizer bar grease		—	Grease nipples (3 pumps max.) every 800 km

# SEAT REMOVAL

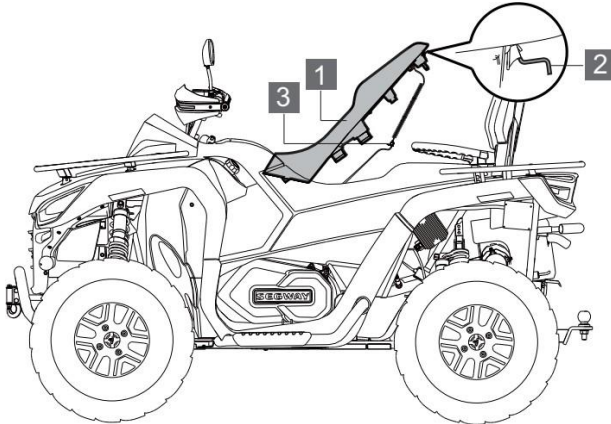

**1** Seat      **2** Seat latch      **3** OPC connector

1. Hook the seat latch with your fingers and move upward;
2. Lift the seat upward after it bounces off;
3. Remove the OPC wiring connector from the seat ;
4. Take the seat off.

## NOTE

There is OPC wire harness connector under the seat. Do not push too hard when you are removing the seat, otherwise the connector can break.

# TANK COVER

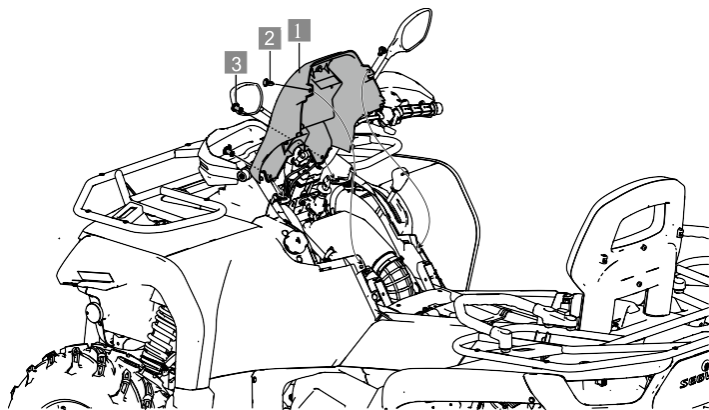

**1** Tank cover

**2** Expansion screws

**3** Hexagon screw

1. Remove the seat (see Page 118);
2. Remove the two expansion screws in front of the tank cover;
3. Remove the two hexagon screws behind the tank cover;
4. Lift the tank cover up.

## NOTE

There are two wire harness connectors at the bottom of the tank cover. If you need to completely remove tank cover, pull out the connectors.

# FRONT MAINTENANCE PANEL REMOVAL

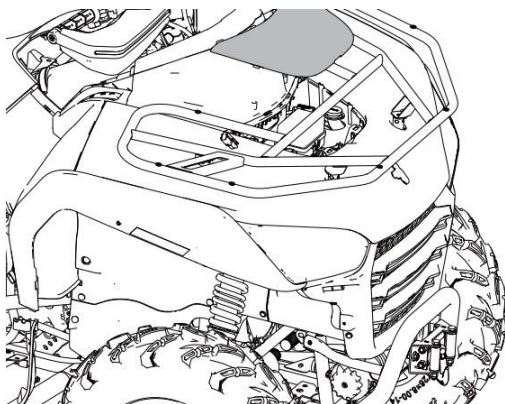

To remove the front maintenance panel:

The front maintenance panel is fast removable snap-type cover - you only need to lift the front of the panel up by hand.

When lifting up the maintenance panel, do not apply too much force to avoid the panel and the rack support bar collision, as this could damage maintenance panel paint.

Coolant recovery bottle cap and fuse box are located under the maintenance cover. Please refer to the maintenance cover removal in this section when adding coolant or replacing the fuse.

# INSTRUMENT COVER REMOVAL

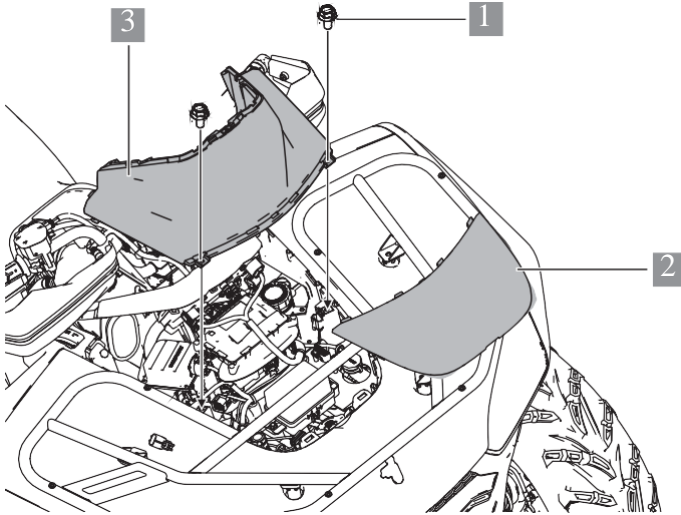

**1 Bolts (2x)**

**2 Front maintenance panel**

**3 Instrument cover**

**To remove the instrument cover:**

1. Remove the front maintenance panel **2** (See Page 120) ;
2. Remove 2 screws of the instrument cover **1** ;
3. Remove instrument cover **3** .



## ENGINE OIL

Be sure to check and change the oil at the time required by the regular maintenance chart. Be sure to use recommended engine oil. Oil filter must be changed after the break-in and every time when the oil is changed. Pay special attention to the oil level. If the oil level is low, add the oil. If the oil level starts to rise (especially in cold weather), stop using the machine and contact an authorized Segway Powersports service.

### **WARNING**

Operation with insufficient, degraded or contaminated engine oil will cause accelerated wear, and may result in engine failure, accident and injury. Always perform the maintenance procedures listed in to Periodic maintenance chart.

## Oil recommendation

**Note:**

Oil filter must be changed every time the oil is changed.

Segway recommends using MAXIMA 10W-40 four-cycle oil for this engine. Please refer to the Lubricating guide section for oil recommendations and capacity.

**Recommended oil:**

Maxima ATV PREMIUM 10W-40

**CAUTION**

Mixing brands or using non-recommended oils may cause serious engine damage. Always use the recommended oil. Never substitute or mix oil brands.

## Engine oil level check

**NOTE**

Running the engine with an improper oil level can cause serious engine damage.

1. Park the vehicle on a level ground. Wait at least 5 minutes to allow the oil to flow back to the bottom of the engine.
2. Put a piece of cotton cloth under the end of the oil dipstick, then unscrew the oil dipstick out.
3. Wipe the oil dipstick clean.
4. Screw in the oil dipstick.
5. Put a piece of cotton cloth under the end of the oil dipstick, then pull out the oil dipstick and check the oil level.

**Note:**

Oil level should be between the Upper mark **1** and Lower mark **2** of the dipstick. Oil below the lower mark means the oil is too low and should be added, oil on the upper level means there is too much oil in the engine.

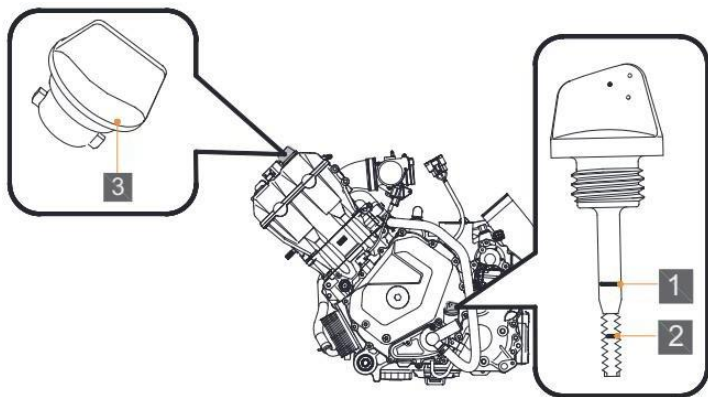

**1** Upper level

**2** Lower level

**3** Oil filler cap

6. After cleaning the oil dipstick, fully insert it again. Do not screw it in.
7. If the oil level is near or below the lower level mark, remove the seat (see Page 118). Remove the oil filler cap **3** on the front right crankcase cover and add the specified oil into the fill cap hole, to the upper level mark on the dipstick.
8. Reinstall the oil fill cap and dipstick.
9. Install the tank cover assembly.
10. Install the seat.

## Changing engine oil and filter

Have the engine oil changed by an authorized Segway Powersports service. As part of the replacement, the service will also clean the oil strainer and replace the oil filter.



### WARNING

- ◆ Used engine oil contains potentially hazardous pollutants, which can cause skin diseases such as dermatitis and skin cancer. Care should be taken to avoid prolonged and repeated exposure to the used oil. Wash the skin thoroughly with soap and hot water to remove engine oil from your skin.
- ◆ Used oil and used oil filter must be disposed in a safe way compliant with environmental regulations. Do not dispose used oil and oil filter in domestic garbage, sewers or on the ground. For information on oil recycling or scrapping, please consult your Segway Powersports dealer.
- ◆ Do not leave used engine oil in a place where children can reach.

## Front / Rear Differential oil and Final Drive oil

Check and replace the gear case oil according to the maintenance schedule.

Use recommended oil only - see Specifications. Use of other oils may cause improper operation of parts.

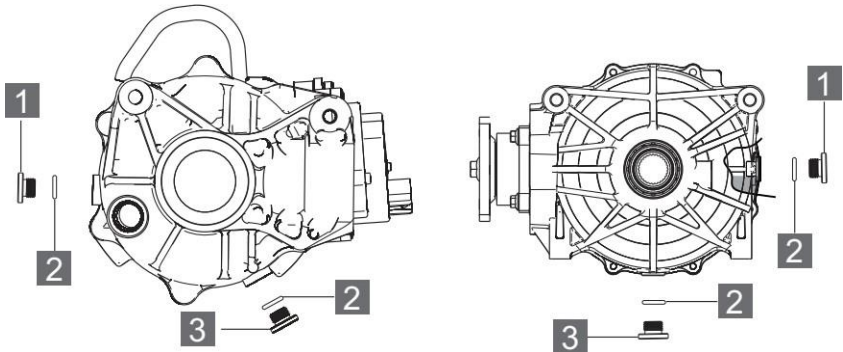

1 Filling plug

2 O-ring

3 Drain plug

### Checking front / rear differential oil / final drive oil:

1. Place the vehicle on the flat level surface
2. Remove the filling plug **1** and O-ring **2** ;
3. Check if the oil level reaches the bottom of the filling hole.

4. Add the recommended oil if needed.
5. Reinstall the O-ring and filling plug.

**Torque to specification :**

Torque	Filling Plug: 16~20Nm
--------	-----------------------

6. Check for the leak.

**Changing the front / rear differential oil / final drive oil**

Have the front / rear differential oil / final drive oil changed by an authorized Segway Powersports service according to the Maintenance chart.

## COOLANT

The coolant circulates in the engine, taking away the excess heat generated during the engine operation and making the engine operate at normal temperature range. Maintaining the coolant will allow cooling system to work properly and prevent freezing, overheating, and corrosion. Check coolant level frequently. Mix antifreeze according to mixing instructions of the coolant liquid used. The coolant needs to be mixed to suit your operating conditions. If you use your ATV in extreme climatic conditions, mixing ratio should be adjusted accordingly. Use only distilled or demineralized water for mixing.

### Adding coolant

The recovery bottle is located on the left side of the vehicle.

1. Observe the coolant level in recovery bottle.
2. If the coolant level is low, remove the cap and add coolant as needed. Maintain the coolant level between minimum **2** and maximum **1** marks on the bottle (when coolant is cool).
3. Remove front maintenance panel (see Page 120);
4. Unscrew the cap, pour in new coolant. Pay attention to the coolant level, do not exceed the maximum mark.
5. Reinstall the recovery bottle cap.



6. Reinstall the front maintenance panel.

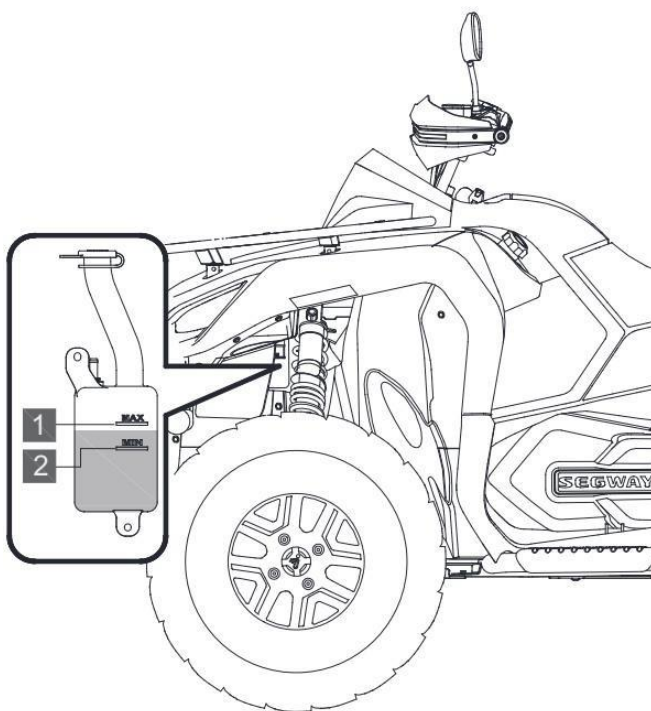

**1** Maximum level

**2** Minimum level

## BRAKE SYSTEM

The front and rear brakes are hydraulic disc brakes that are activated by brake pedal or hand lever. Brakes are self-adjusting. As the brake pads wear, brake fluid level will be dropping slowly. Leakage in the brake system can also cause the brake fluid to drop.

### WARNING

Check brake fluid level periodically. Overfilling the brake cylinder may cause brake drag or brake locking, which may result in serious injury or death. Keep brake fluid at the recommended level, do not overfill. You must check brake pads wear and brake disc condition regularly. If brake pads or disc wear, they should be replaced.

The following inspection is recommended to keep the braking system in good condition. If the brake is in heavy use, check it more frequently.

1. Always keep the brake fluid at an correct level.  
Please refer to master cylinder/brake fluid section for details.
2. Check the braking system for leakage.
3. Check whether the brake travels too long or feels soft.

4. Check whether the brake pads are worn, damaged or loose. Brake pads must be replaced when remaining thickness is 1 mm.
5. Check the surface and condition of the brake disc. Use recommended brake cleaner to clean any grease. Do not use spray lubricants or other petroleum-based products. If any damage (crack, excessive corrosion, warping) is found, please visit Segway Powersports service before operation.

## Brake fluid

Recommended brake fluid:

Brake fluid	DOT4
-------------	------

No adjustment is required for the hydraulic brake system. Check the brake fluid level frequently. If the level is low, add brake fluid. The brake fluid reservoir is located under the front instrument cover.

1. Remove front maintenance panel and instrument cover. See Pages 120 - 121 for removal.
2. Check the fluid level in the reservoir

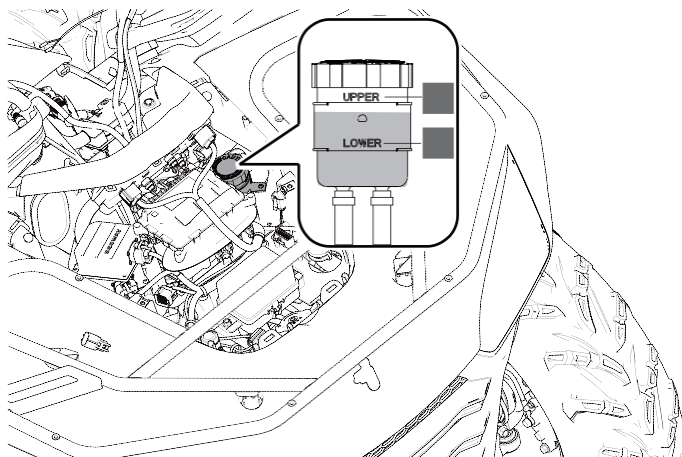
**1** UPPER**2** LOWER

3. The brake fluid level should be between the upper and the lower marks. If it is lower, add the recommended brake fluid and check the fluid level.
4. Check whether the brake pads are worn.

**NOTE**

Brake fluid can damage plastic and painted surfaces and should be handled with caution. If the brake fluid comes into contact with the skin or eyes, flush with plenty of water immediately. If you feel sick, seek medical immediately.

## Front brake fluid

Check whether the front brake fluid level is above the minimum level mark on the right handlebar. When the fluid level is below the minimum, add brake fluid.

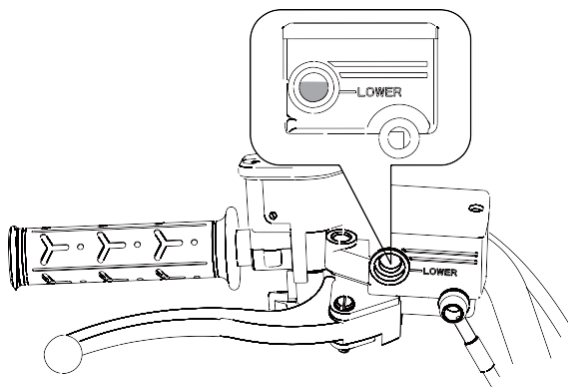

### **LOWER mark - minimum brake fluid level**

1. Check brake fluid frequently.
2. Check frequently whether the brake pads are worn.

## Brake Pad Inspection

Brake pads wear will depend on the severity of usage and operating conditions. Brake pads wear faster in wet and muddy conditions. Periodically inspect brake pads for thickness according to maintenance periodic table. If brake pad thickness is 1.00 mm or less, brake pads must be replaced.

Brake pad thickness	Standard thickness	5.0 mm
	Minimum thickness	1.0 mm

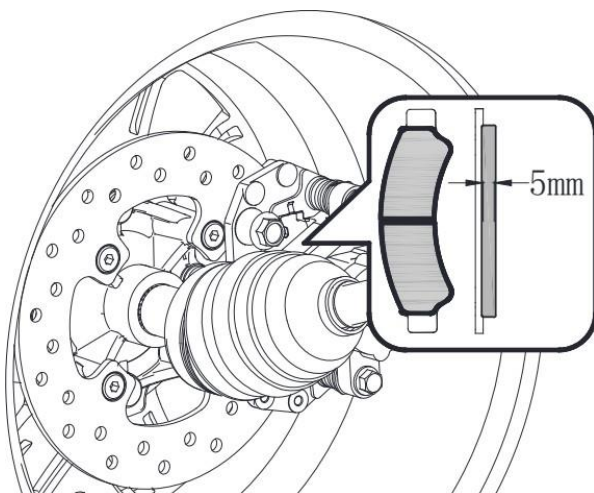

# TIRES

## Tire pressure

Driving a vehicle with incorrect tire pressure may result in:

- ◆ Reduced fuel efficiency
- ◆ Reduced driving comfort and shortened tire life
- ◆ Reduced ride safety

When checking tire pressure, follow these recommendations:

Tire pressure	Front	Rear
	48 kPa	48 kPa

- ◆ Check tire pressure only after the tire cools down.
- ◆ If the vehicle has been parked for at least 3 hours, or has not driven more than 1.5km, checking at this time will get an accurate reading of the cold tire pressure.
- ◆ Use low-pressure ATV tire pressure gauges. Tire appearance can sometimes be misleading. In addition, even a few kPa less air in a tire can affect driving and handling performance.
- ◆ Don't reduce tire pressure after the ride. Increased tire pressure after driving is normal.

## Tire tread depth

- ◆ Observe the tire shoulder to find the Tread wear indicator "T.W.I.". When the tire tread block wears to the wear limit mark, exchange the tire. Otherwise the tire can burst underway due to insufficient strength.
- ◆ Always replace tires when the tread depth is worn to limit.

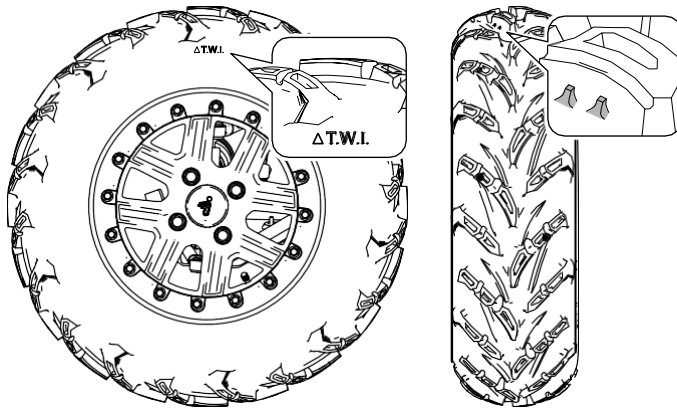

Tread wear indicator “T.W.I”



## When to Change a tire

### A tire should be changed if:

- ◆ Tire is damaged - cuts, delaminations, deep cracks, bulges indicating the tire carcass is damaged etc.
- ◆ Tire has steady air leak and cannot be normally repaired due to the size or position of the puncture, or has other damage. If you are not sure, consult your dealer.

## Wheels removal

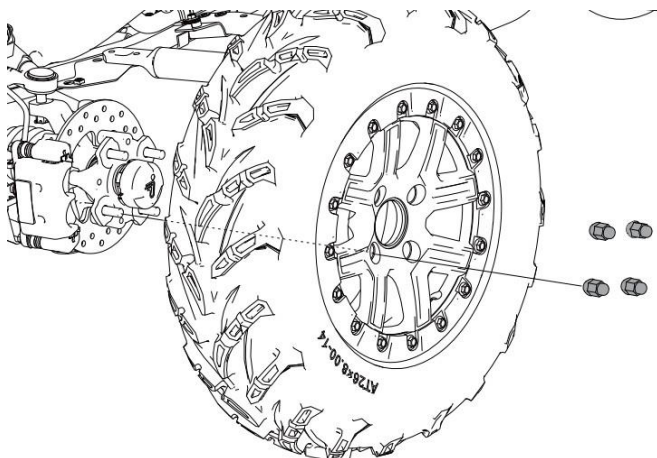

**Tightening torque :**

Torque

Wheel nuts: 70-80 Nm

1. Stop the engine.
2. Place the transmission in Park ("P" position).
3. Lock the Parking brake.
4. Loosen the wheel nuts slightly.
5. Lift the side of the vehicle by placing a suitable jack or stand under the foot rest frame.
6. Loosen and remove 4 wheel nuts.
7. Remove the wheel.

**CAUTION**

Loose nut may cause wheel to come off during ride, which may cause an accident or rollover. Always ensure that all nuts are tightened to 70-80 Nm. Do not use lubricating oil or grease on wheel bolts / nuts. Lubricating oil / grease may cause excessive tightening of wheel nuts, resulting in damage to bolts or wheels. In addition, lubricating oil or grease can cause wheel nuts to become loose and wheels may come off, which can lead to accidents and serious injuries. Clean all lubricating oil or grease from wheel bolts / wheel nuts.

## Tire replacement

**▲ WARNING**

Do not use wheels of different sizes than recommended in this manual as this can cause the vehicle to lose control.

	Front	Rear
Recommended tire size	25×8-12/26×8-12	25×10-12/26×10-12

## SHOCK ABSORBERS ADJUSTMENT

There are different types of shock absorbers fitted, depending on the model / variant. Please adjust shock absorber according the actual type fitted to your ATV.

### Oil shock absorber

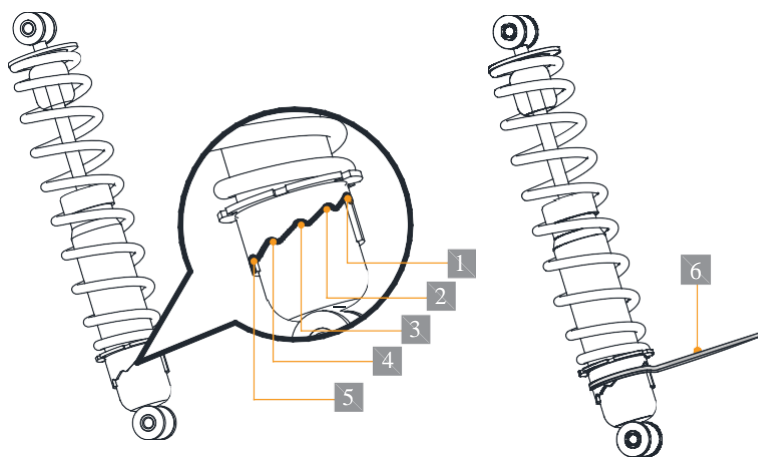

There are 5 spring preload positions for different loads and driving conditions on this shock absorber:

**Position 1:** For light loads or flat terrain

**Position 2:** Standard position

**Position 3 ~ 5:** For high loads and heavy cargo

1. Use hook wrench **6** to adjust the spring preload.

**CAUTION**

When adjusting the shock absorbers, always adjust absorbers on the left and right side to the same setting. Change up or down only one position at a time when adjusting. Do not try to make large adjustments, which may damage the shock absorber.

## Adjustable shock absorber

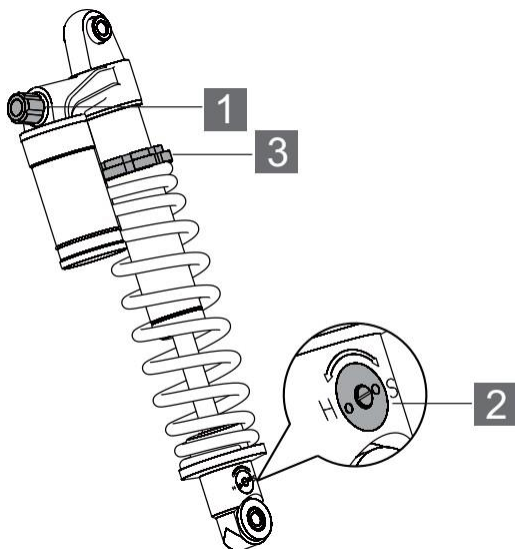

## 1 **Compression damping adjusting knob**

- ◆ Increase the compression damping by turning the knob clockwise.
- ◆ Reduce the compression damping by turning the knob counterclockwise.

## 2 **Rebound damping adjusting screw**

### **Use flat screwdriver to adjust the screw**

- ◆ Increase rebound damping by turning the screw in the direction “H”.
- ◆ Reduce rebound damping by turning the screw in the direction “S”.

## 3 **Spring preload**

### **Use hook wrench to adjust the spring preload**

- ◆ Reduce the compression pressure when turn the adjusting cap upwards
- ◆ Increase the compression pressure when turn the adjusting cap downwards

## SUSPENSION LUBRICATION

Front suspension, rear suspension, drive shafts and stabilizer bar are provided with grease nipples. A grease filling label is placed nearby.

Grease filling label:

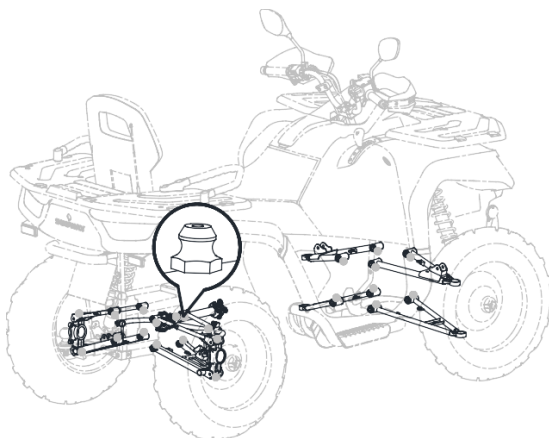

All these parts need sufficient lubrication, see Periodic maintenance table. Sufficient lubrication can reduce the wear of these parts, and increase the service life.

## FRONT AND REAR AXLE BOOTS

### Front axle boots

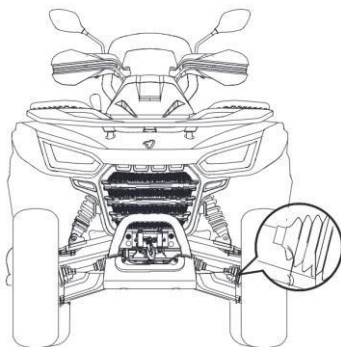

### Rear axle boots

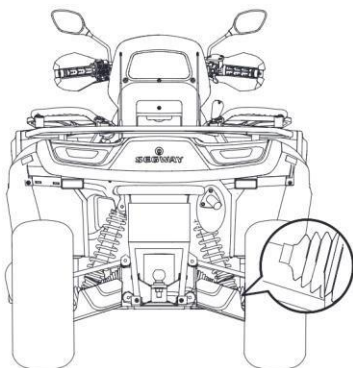

Inspect the front and rear drive shafts ball joint boots for cracks, tears, perforations or grease leakage. If needed, contact an authorized Segway Powersports dealer for service.



## AIR FILTER

The air filter of this vehicle is paper filter element. Air filter needs to be regularly cleaned and replaced, see the periodic maintenance table (Page 114) for details. First, remove the filter element for inspection. If the filter element is seriously soaked with oil or dust, do not clean it, and instead replace it with a new filter element. If there is no oil or heavy dust, put the air filter element with intake side down, knock on the ground, and shake off most of the dust.

It is better if you have compressed air - you can blow from the filter element side (do not blow from the air intake side), until the dust is blown off.

## Removing the filter cover

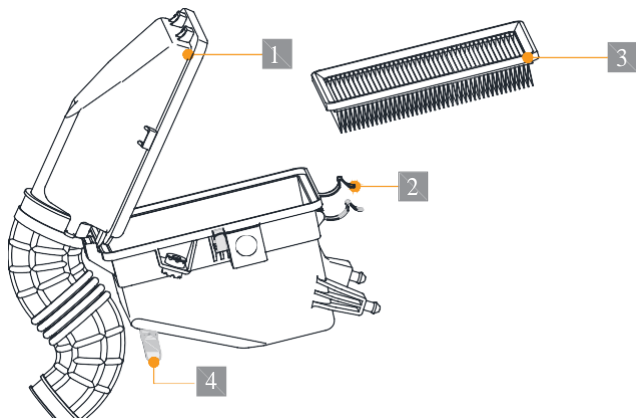

**1 Air filter cover**

**2 Air box cover clamp**

**3 Air filter element**

**4 Air filter plug**

Air filter cover is located in front of the seat.  
(Seat removal, see Page 118).

1. Press and lift the air box cover clamps.
2. Pull up the front of air filter cover;
3. Take out the air filter.
4. Clean the filter;
5. Install a new filter if needed.
6. Make sure the air filter is securely fixed.

# LIGHTS

**CAUTION**

Poor lighting can result in reduced visibility while driving. If the headlights and taillights get dirty, clean them promptly. Replace burnt lamps / bulbs immediately. To ensure optimum visibility, make sure the lights are properly adjusted.

## Headlights replacement

### LED lights

LED lights consist of multiple lights. Have your dealer replace the entire assembly if an LED is damaged or has failed.

### Halogen lights

Burned out halogen bulb can be replaced. You can replace the following lamps by yourself. Difficulty of replacement varies according to the bulb types. Due to possible damage, we recommend that these parts are better to be replaced by the dealer.

When there are big beads of water inside the lens, or water condensation inside the headlamp, contact your dealer for more information. It doesn't mean malfunction if condensed water appears inside the headlamp lens temporarily.

**CAUTION**

Hot parts can cause skin burns. Allow the lights to cool before performing any maintenance.

DO NOT touch the headlight bulb glass. Fingerprints on the glass can cause premature failure.

**Headlight lamp replacement:**

1. Remove the headlamp screws and headlamp cover.

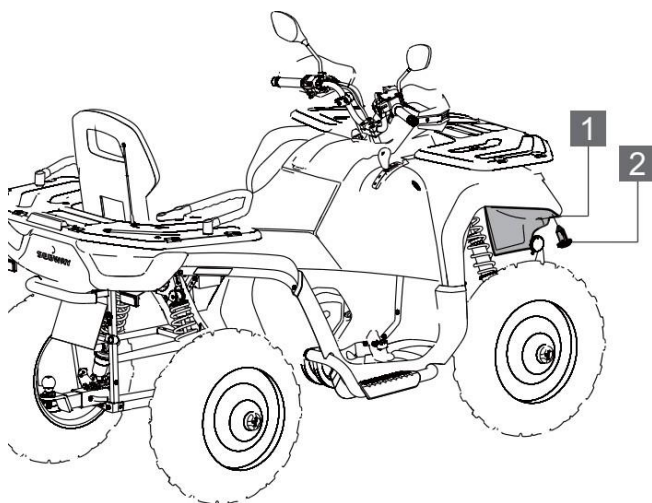

**1 Front headlamps cover**

**2 Expansion screw**

2. Turn the rear headlamp cover clockwise and take it off.

3. Unplug wire harness connector from the lamp and remove the broken lamp.

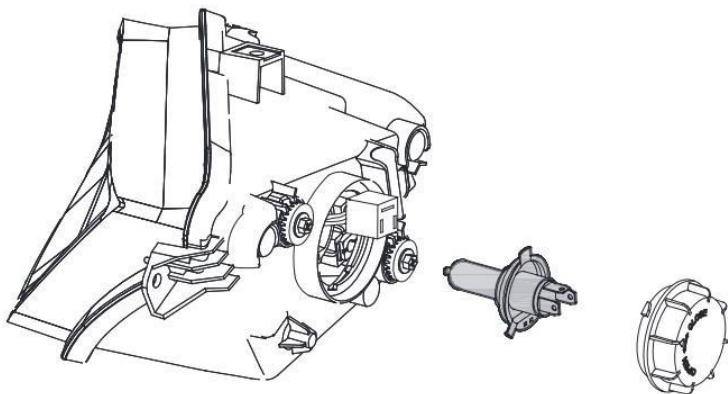

4. Reinstall the new light into the headlight and turn on the lights. Test whether light is working properly.
5. Press the fixed spring on both sides to make the spring pop out of the slot.
6. Remove the broken bulb.

**CAUTION**

Replace the bulb with new one of the same type and rating.

Reinstall new lamp into the new headlight. Installation is reverse of disassembly. After installation, turn on the headlights to test whether the lamp is working properly.

## Taillight / rear turn light replacement

### To change taillight:

Remove rear light cover.

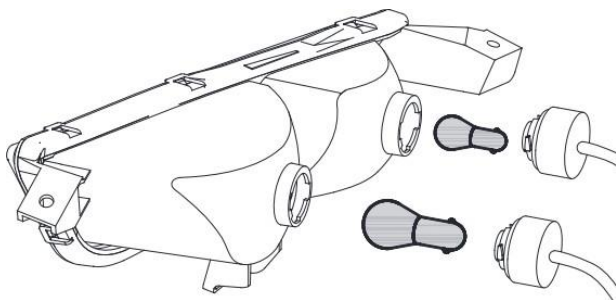

1. Unscrew the rear light holder.
2. Turn the bulb to be replaced counter-clockwise. When the limit bead at the end of the bulb gets stuck in the bulb seat slot, damaged bulb can be taken out and replaced with a new bulb of the same type and rating.
3. Test if the light works normally.

## High Beam Adjustment

The headlight beam can be adjusted up/down and left/right. Use following procedure for adjustment.

### CAUTION

The following image is for reference only. Your model may be slightly different.

It is best to let Segway Powersports dealers adjust if conditions permit.

1. Place the vehicle on a flat ground with a headlight approximately 10 m from the wall.

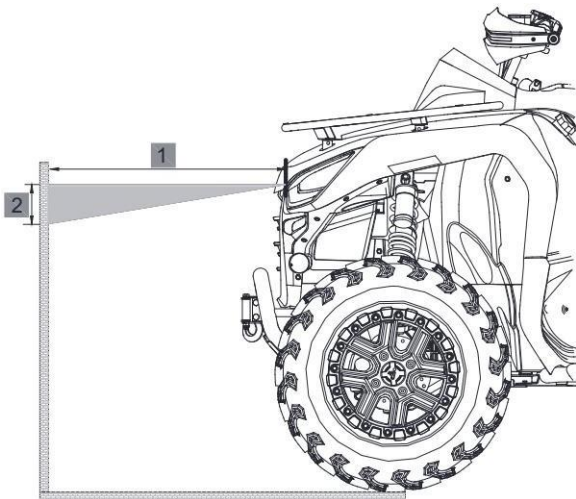

2. Measure the distance from the floor to the center of the headlights and make a mark on the wall at the same height.
3. Start the engine. Switch headlights to high beam.
4. Watch the headlight aim on the wall. The most intense part of the headlight beam should be 5cm below the mark on the wall. Measure the headlight aim with the weight of the driver on the front seat.

### Adjusting the headlight beam up and down

To raise the headlight beam, turn the headlight adjusting screw in direction (L). To lower the headlight beam, turn the headlight adjusting screw in direction (R).

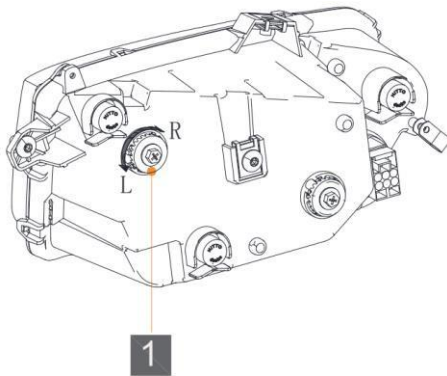

**1** Vertical adjusting screw



## Adjusting the headlight beam left and right

Headlight beam can be adjusted slightly to the left or right.

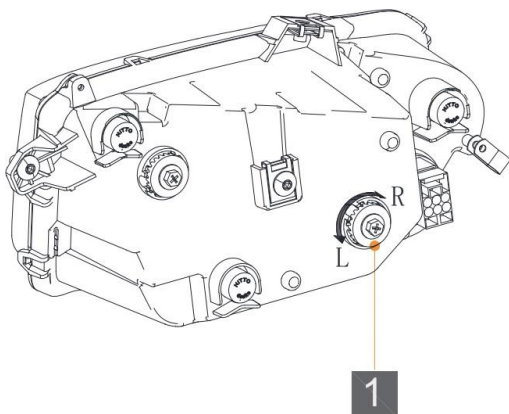

### 1 Horizontal adjusting screw

To adjust the headlight beam to the left, turn the headlight adjustment screw in direction (L).

To adjust the headlight beam to the right, turn the headlight adjustment screw in direction (R).

# SPARK PLUG

Refer to the recommended spark plug type and spark plug gap specifications. Spark plug torque to specifications.

## CAUTION

Using non-recommended spark plugs can cause serious engine damage. Always use the recommended spark plugs or their equivalents.

Spark plug	Type	Spark plug gap
	NGK CPR7EA	0.6-0.8 mm

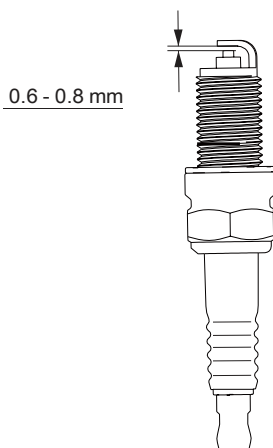

## Spark plug inspection

Spark plug condition indicates how the engine is running. Check or change the spark plug according to periodic maintenance chart.

### CAUTION

Remove the spark plug for inspection need wear protective gloves, or hot exhaust system and engine will cause burns.

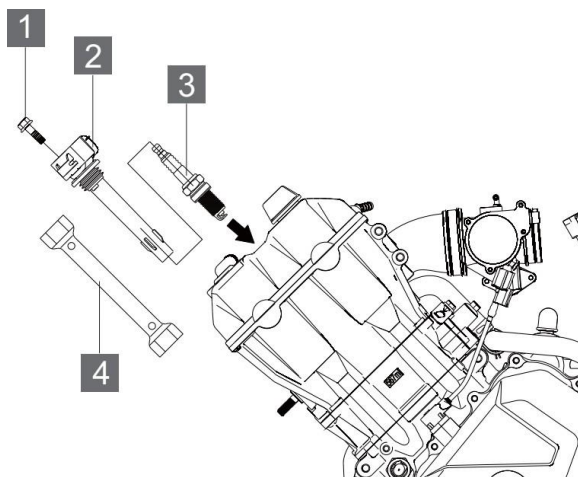

1 Bolt

2 Ignition coil

3 Spark plug

4 Extended spark plug sleeve

Spark plug is located under the seat. Refer to Page 118 for removing the seat.

1. Remove the ignition coil fixing bolt;
2. Remove the ignition coil;
3. Spark plug is located under the ignition coil. Use tool to turn the spark plug sleeve 1/4 turn and remove it from the spark plug.
4. Rotate spark plug counter-clockwise and remove it.
5. Inspect spark plug.

**Spark plug normal status:**

The insulator tip is light gray, grayish yellow or light brown, spark plug gap is about 0.6-0.8 mm.

**Spark plug to be replaced:**

The insulator tip is black. If there is electrode ablation, carbon deposition, or gap is too large, spark plug should be replaced.

## SPARK ARRESTOR

Spark arrestor prevents random sparks from entering other vehicles parts. Regular maintenance can prevent carbon deposits; delayed maintenance will reduce engine performance.

### WARNING

Make sure the engine has stopped running and the exhaust pipes are cool. Let pipes completely cool down to avoid heavy burns.

To reduce fire hazard, ensure that there are no combustible materials nearby when removing spark plugs.

Safety glasses are recommended in this procedure.

Exhaust pipe must be periodically cleaned of carbon deposits as follows:

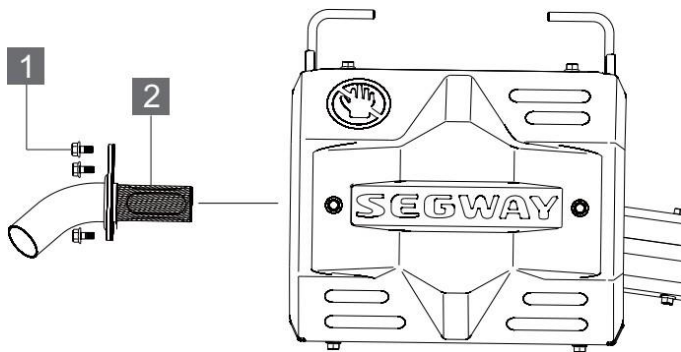

**1 Bolt M6x16 (3x)**

**2 Spark arrester**

1. Remove 3 bolts M6x16.
2. Start the engine and rev it up about 20 times. At the same time, use a towel to plug the end of the muffler, instantly generating pressure in the exhaust system.
3. Let the exhaust pipe to cool.
4. Reinstall spark arrester and bolts.

## BATTERY

Your ATV is equipped with a sealed MF battery, which requires little maintenance. It is not necessary to check the electrolyte or add distilled water to the battery. Due to natural discharge and power consumption of some electrical equipment, battery will discharge gradually even when the vehicle is not in use. If the vehicle is parked for a long time, the battery may discharge and may not start the engine. Charge the battery every 30 days. This will maintain the battery life.

### ▲ WARNING

12V batteries contain toxic and corrosive sulfuric acid and may produce flammable explosive hydrogen gas. To reduce the risk of serious injury or death, following precautions should be observed when handling 12V batteries or working near them:

- ◆ Do not smoke or light matches near a battery.
- ◆ Avoid electrolyte contact with eyes, skin and clothes.
- ◆ Wear safety goggles when working near the battery.
- ◆ Keep children away from 12V batteries.

Be sure to charge the battery in an open area. Do not charge battery in a poorly ventilated garage or enclosed room.

## Battery removal

Battery is located under the seat. Refer to the Page 118 for seat removal. Switch the ignition key to OFF position before removing the battery.

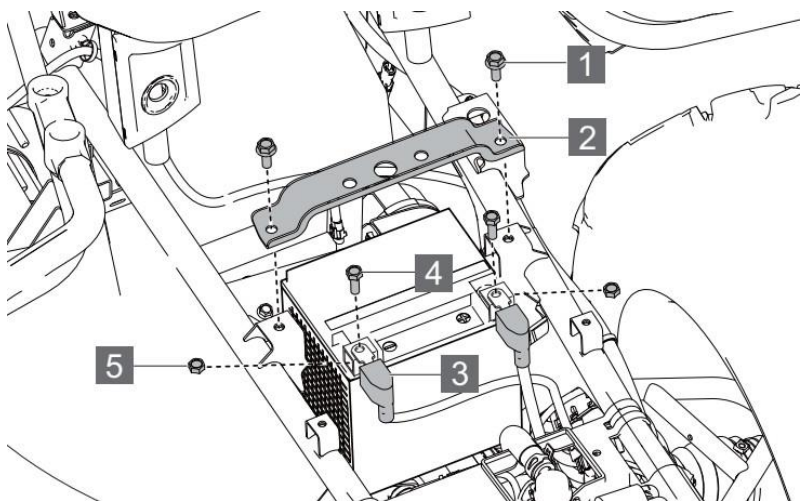

1 Bolt M8 x 12 (2x)

2 Battery plate

3 Terminal rubber covers

4 Terminal bolts

5 Terminal nuts



1. Unscrew the battery plate screws **1** ;
2. Remove battery plate **2** ;
3. Pull the terminal rubber covers off ;
4. Remove terminal screw and disconnect black (negative) cable first.
5. Remove the terminal screw and disconnect red (positive) cable.
6. Remove battery from the ATV.

## Battery Charging

### CAUTION

When charging, the 12V batteries produce hydrogen, combustible and explosive gas. Therefore, please follow the following precautions before battery charging:

If charging battery which is still installed in the ATV, be sure to disconnect the ground cable.

Make sure the charger is off when connecting and disconnecting the clamps to the battery.

Only charge slowly (5A or less). If charged quickly, the batteries may explode.

## Battery installation

**NOTE**

To reduce the chance of sparks: Whenever the battery is removed, disconnect the black (negative) cable first. When reinstalling the battery, finally install the black (negative) cable.

1. Clean battery terminals with a soft wire brush and contact cleaner, such as the Maxima Electrical Contact / Brake Cleaner. Finally, coat the terminals and bolts with electrical contact grease.
2. Insert the battery in the tray.
3. Connect and tighten the red (positive) cable.
4. Connect and tighten the black (negative) cable.
5. Install a clear battery vent from the vehicle to the battery vent. (For conventional batteries only).
6. Install the battery plate;
7. Tighten the battery terminal bolts;
8. Check that cables are properly routed.

## Jump-starting

1. Connect positive clamp of the jumper cable to the positive (+) terminal of the flat battery in your ATV.
2. Connect the other clamp of the jumper cable to the positive (+) terminal of the battery in another vehicle.
3. Connect negative clamp of the jumper cable to the negative (-) terminal of the battery in your ATV.
4. Connect the other negative clamp of the jumper cable to the negative (-) terminal of the battery in another vehicle.

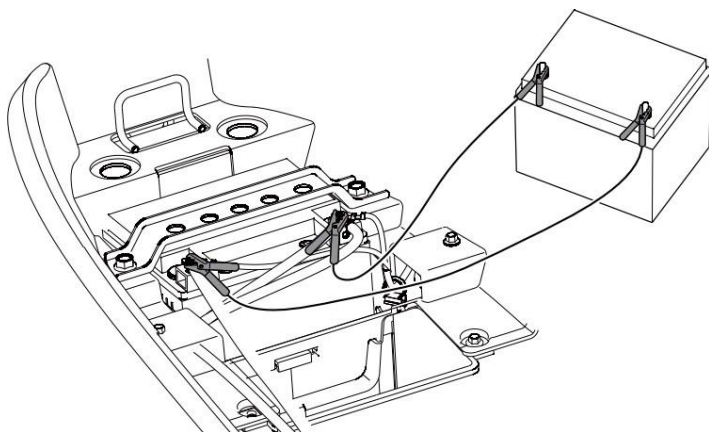

## FUSES

All circuits on this ATV are protected with fuses to protect electrical systems from damage by high current (short-circuit or overload).

If there is any electrical system failure, always check the fuses first. You can consider electrical faults. If the fuse is blown, replace it with a fuse of the same type and rating. There are several spare fuses in the fuse box. Check all other fuses for possible cause. Replace all blown fuses and check the electrical system. All fuses are located in the fuse box. In the event of a system failure, see "Fuse/relay ratings and location" for details.

### NOTE

- ◆ Always replace a blown fuse with the fuse of the same type and rating.
- ◆ Do not replace the fuse with anything else.
- ◆ Never use wires instead of the proper fuses - even as a temporary replacement this is strictly prohibited.
- ◆ If the fuse immediately blows again, contact your dealer.

## Fuse box

Fuse box is located under the front maintenance cover. For front maintenance cover removal see Page 120.

After the front maintenance cover is removed, the fuse box is located at the bottom. Move the locking tabs on the sides of the fuse box cover to the outside. Loosen the tabs and open the fuse box.

### NOTE

When installing the fuse box cover, pay attention to the orientation of the cover and locking tabs.

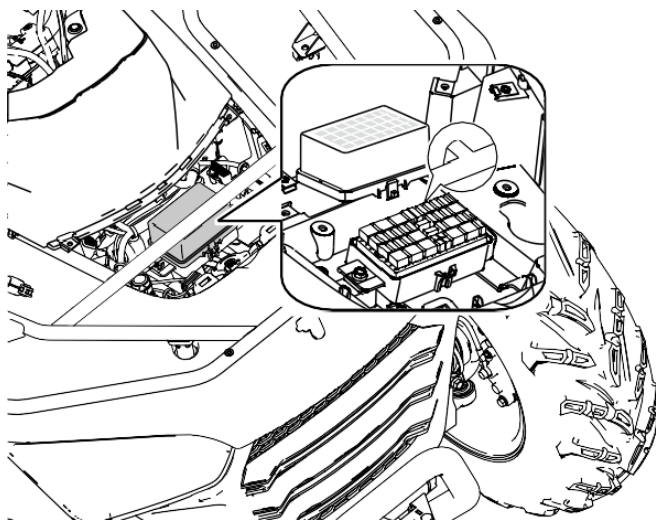

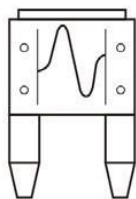

Normal fuse

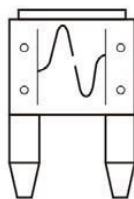

Blown fuse

## Fuse / relay ratings and location

There is a fuse location and rating scheme on the top of the fuse box cover. Refer to this scheme when finding a fuse for replacement.

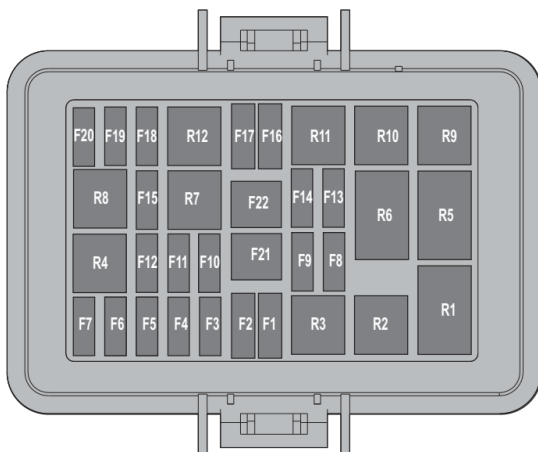

Fuse / relay ratings and location

No.	Fuse/Relay	Rating
F1	Buzzer and OBD ICU	5A
F2	Start ECU	AT6 S: 5A AT6 L: 7,5A
F3	IGNTE	10A
F4	2WD / 4WD	10A
F5	Light speaker	15A
F6	ICU-IG	7,5A
F7	DTS-IG	5A
F8	DTS	5A
F9	KEY	5A
F10	EPS-IG	5A
F11	12V Auxiliary outlet / USB Port	15A
F12	Pos-Lamp-L	7.5A
F13	Fuel pump	10A
F14	Head light	25A
F15	Pos-Lamp-R	7,5A
F16	FAN	15A
F17	FUEL INJECTOR	10A
F18	ECU	10A
F19	OXYGEN SENSOR	10A

F20	IGNITION COIL	10A
F21	MAIN FUSE	30A
F22	EPS	50A
R1	4WD relay 1	12V 20A
R2	DTS relay	12V 20A
R3	IG relay	12V 20A
R4	Main relay	12V 20A
R5	4WD relay 2	12V 20A
R6	ECU-4WD relay	12V 20A
R7	Low Beam relay	12V 20A
R8	High Beam relay	12V 20A
R9	Auxiliary start relay	12V 20A
R10	Day light relay	12V 20A
R11	Fuel Pump relay	12V 20A
R12	Fan relay	12V 20A



## Fuse replacement

Before checking or replacing the fuse, turn ignition switch to (OFF) to prevent accidental short circuit.

To check or replace the fuse, pull out the blown fuse with a fuse puller in the box cover. Using this tool will help you take out the fuse.

Fuse box cover is also fitted with a spare fuses which can be replaced.

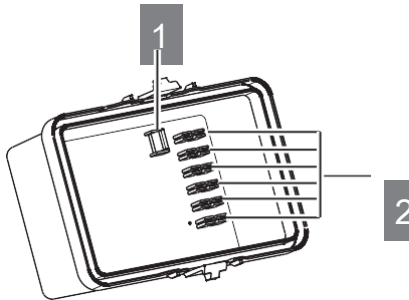

**1** Fuse puller

**2** Spare fuse

### NOTE

If the correct fuse suitable for the circuit is not available, install next lower rated fuse.

## APPEARANCE CARE

### **Car wash not recommended.**

Pressure water can damage parts and remove paint and decals.

1. Cover or plug the exhaust outlet prior to washing your ATV.
2. Fill a bucket with water. Add mild neutral detergent, preferably product made especially for washing motorcycles or cars.
3. Wash your ATV with a sponge or soft towel. As you wash, check for heavy grime. If necessary, use a mild cleaner/ degreaser to remove the grime.
4. After washing, rinse your ATV thoroughly with plenty of clean water to remove any residues. Detergent residues can corrode alloy parts.
5. Dry your ATV with a chamois or a soft towel. Leaving water on the surface to air dry can cause dulling and water spots. As you dry, inspect for chips and scratches.
6. Ride your ATV at a slow speed and apply the brakes several times. This will help dry the brakes and restore normal braking performance.

## **Cleaning the vehicle**

Wash the vehicle immediately after driving in salty or corrosive environment.

It is recommended that you clean your vehicle with mild automotive cleaners. Follow instructions on the container.

## **Cleaning tips**

Avoid using harsh and abrasive products, some of which may scratch your vehicle. Clean and polish regularly with a clean cloth and mat. Old or reused cloth and mats can contain dirt particles that can scratch the finish.

## **Vehicle storage**

When the vehicle is not used for a long time, it should be appropriately stored. The vehicle should be serviced and thoroughly cleaned prior storing. Avoid using a plastic cover as moisture will collect on the ATV causing rusting. Best storage is well ventilated indoor storage. For storage, use a battery maintainer or charge the battery regularly.

# **SPECIFICATIONS**

<b>TECHNICAL SPECIFICATIONS.....</b>	<b>174</b>
<b>VEHICLE IDENTIFICATION NUMBERS</b>	<b>179</b>
<b>IDENTIFICATION PLATE.....</b>	<b>180</b>

# TECHNICAL SPECIFICATIONS

	Model	
	AT6-S	AT6-L
Length	2200 mm	2350 mm
Width	1280 mm	1280 mm
Height	1430 mm	1430 mm
Wheelbase	1320 mm	1450 mm
Ground clearance	270 mm	270 mm
Turning radius	7000 mm	8000 mm
Curb weight (no oil and gasoline)	390 kg	398 kg
Front rack load	40 kg	
Rear rack load	60 kg	
Pulling capacity	1028 kg (off-road)	1028 kg (off-road)

Engine	199MS
Engine type	Four stroke, single cylinder, water cooled, DOHC
Bore × Stroke	99×73.6 mm
Displacement	567ccm
Compression ratio	10.6 : 1
Maximum power	32.5 kW / 7000 rpm
Maximum torque	48 Nm / 5500 rpm
Idle speed	1400±140 rpm
Starting system	Electric
Lubrication	Wet Sump
Engine oil type	MAXIMA 10W-40
Engine oil capacity ( with oil filter replacement )	2.4L
Engine oil capacity ( without oil filter replacement )	2.2L
Front axle gear oil	SAE75W/90 GL-5
Change volume	260ml

Rear axle gear oil	SAE 80W/90 GL-5/ SAE 75W/90 GL-5
Oil change volume	240ml
Air filter	Paper filter
Fuel tank type	Flame-retardant plastic fuel tank
Fuel tank capacity	23L
Fuel reserve	4.5L
Spark plug type	NGK CPR7EA
Spark plug gap	0.6~0.8 mm
Transmission	CVT + Gearbox
Shifting sequence	L-H-N-R-P
CVT ratio	0.648~2.976
L Transmission ratio	5.34
H Transmission ratio	3.08
Reverse gear ratio	4.40
Tire type	Tubeless
Front tires	25×8-12/26×8-12

Rear tires	25×10-12/26×10-12
Front tire pressure	48 kPa
Rear tire pressure	48 kPa
Brake type	Hydraulic disc
Foot brake	Right foot operation
Front brake	Right hand operation
Brake fluid type	DOT4
Front suspension	Double A-Arm
Rear suspension	Double A-Arm with stabilizer
Front shock absorber	Hydraulic shock / Adjustable hydraulic piggyback shock (see your model)
Rear shock absorber	Hydraulic shock / Adjustable hydraulic piggyback shock (see your model)
Front wheel travel	185 mm
Rear wheel travel	210 mm
Ignition	ECU
Alternator	450W / 5500 rpm
Battery	Fulbat 12V 30Ah (YTX30L-BS)



<b>Lighting</b> (check your model)		
Headlights	LED 13.2W	H4 55W/60W
Front turn signal lights	LED 2.64W	4.8W
DRL lights	LED 28.8W	4.2W
Front position lights	LED 12W	0.5W
Rear turn signal lights	LED 2.64W	10W
Brake lights	LED 3.96W	21W/5W
Taillights	LED 0.61W	
License plate light	5W	

## VEHICLE IDENTIFICATION NUMBERS

Record the Vehicle identification number and engine serial number in the spaces provided for ordering spare parts from a dealer or for reference in case the vehicle is stolen.

Vehicle identification number is stamped on the frame under the seat.

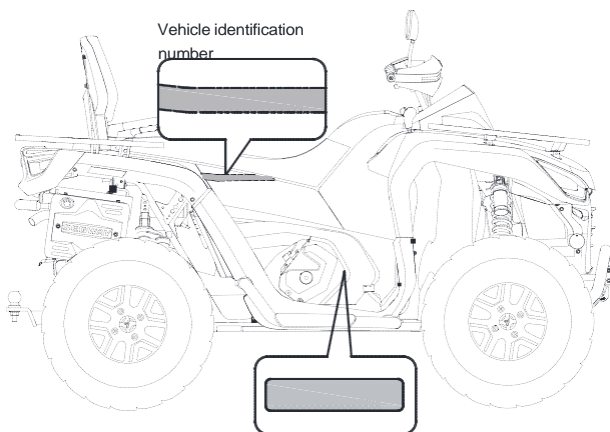

Engine serial number

**VIN Number:**

**Engine serial number:**

## IDENTIFICATION PLATE

Vehicle's identification plate is located on the left side of the vehicle, under the rear rack. Identification plate contains basic vehicle information including VIN number. You will need VIN number for the first vehicle activation.

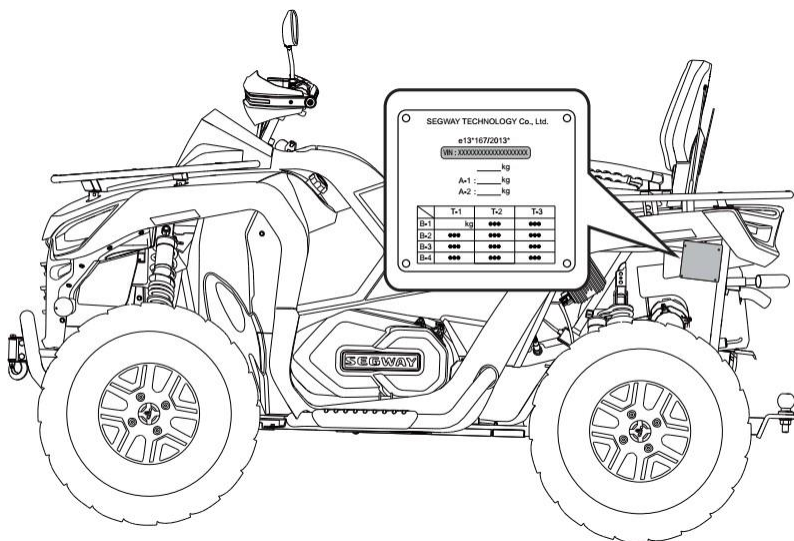

# TROUBLESHOOTING

Drive belt wear / burn.....	182
Engine doesn't turn over .....	184
Engine pings or knocks.....	184
Engine stops or loses power .....	185
Engine turns over, fails to start... ..	185
Engine backfires.....	186
Engine runs irregularly, stalls or misfires .....	187
Engine runs irregularly, stalls or misfires... ..	187
Engine stops or loses power.....	189

With all the challenges you can encounter in off-road riding, there's chance that sometimes something may go wrong. This section gives you practical advice to help you deal with a wide range of problems. Take time to read this section before you ride.

## Drive belt wear / burn

Possible cause	Solution
Driving onto a pickup or tall trailer in high range	Shift transmission to low range prior to loading ATV to prevent belt burning
Starting out going up a steep incline	When starting out on an incline, use low range
Driving at low RPM or low speed (approximately 5-10 km/h)	Drive at a higher speed or use low range more frequently. The use of low range is highly recommended for lower CVT operating temperatures and longer component life.
Insufficient warm-up at low ambient temperatures	Warm the engine before driving, the belt will become more flexible and prevent belt burning

Possible cause	Solution
Slow / easy clutch engagement	Use the throttle quickly and effectively for efficient clutch engagement
Towing/pushing at low RPM/low speed	Use Low range only
Utility use/plowing snow, dirt, etc	Use Low range only
Stuck in mud / snow	Shift the transmission to low range, and carefully use fast, aggressive throttle application to engage clutch. <b>WARNING:</b> Excessive throttle may cause loss of control and vehicle overturn
Climbing over large objects from a stopped position	Shift the transmission to low range, and carefully use fast, brief, aggressive throttle application to engage clutch. Excessive throttle may cause loss of control and vehicle overturn
Belt slippage from water or snow ingestion into the CVT system	Remove the CVT cover , drain the water from CVT
Clutch malfunction	Contact your dealer for inspection of clutch components

## Engine doesn't turn over

Possible Cause	Solution
Poor engine performance	Check for fouled spark plug or foreign material in gas tank, fuel lines, or throttle. Contact your dealer for service
Tripped circuit breaker	Reset the breaker
Low battery voltage	Recharge battery
Loose battery connections	Check all connections and tighten
Loose solenoid connections	Check all connections and tighten

## Engine pings or knocks

Possible Cause	Solution
Poor quality or low octane fuel	Replace with recommended fuel
Incorrect ignition timing	Contact your dealer for service
Correct spark plug gap or heat range	Set gap to specs or replace plug

## Engine stops or loses power

Possible Cause	Solution
Overheated engine	Clean radiator screen and core Clean engine exterior Contact your dealer for service

## Engine turns over, fails to start

Possible Cause	Solution
Out of Fuel	Refuel
Clogged fuel valve or filter	Inspect and clean or replace
Water is present in fuel	Drain the fuel system and refuel
Fuel valve is out of use	Replace
Old or non-recommended fuel	Replace with new fuel
Fouled or defective spark plug(s)	Inspect plug(s), replace if necessary
No spark to spark plug	Inspect plug(s), verify stop switch is on
Crankcase filled with water or fuel	Immediately contact your dealer for service



Clogged fuel injector	Clean or replace new fuel injector
Low battery voltage	Recharge battery
Mechanical failure	Contact your dealer

## Engine backfires

Possible Cause	Solution
Weak spark from spark plug	Inspect, clean and/or replace spark plug
Incorrect spark plug gap or heat range	Set gap to specs or replace plug
Old or non-recommended fuel	Replace with new fuel
Incorrectly installed spark plug wires	Contact your dealer for service
Incorrect ignition timing	Contact your dealer for service
Mechanical failure	Contact your dealer

**Engine runs irregularly, stalls or misfires**

Possible Cause	Solution
Fouled or defective spark plug	Inspect, clean and/or replace spark plug
Worn or defective spark plug wires	Contact your dealer for service
Incorrect spark plug gap or heat range	Set gap to specs or replace plug
Loose ignition connections	Check all connections and tighten
Water present in fuel	Replace with new fuel
Low battery voltage	Recharge battery

**Engine runs irregularly, stalls or misfires**

Possible Cause	Solution
Kinked or plugged fuel / vent line	Inspect and replace
Incorrect fuel	Replace with recommended fuel
Clogged air filter	Inspect and clean or replace
Reverse speed limiter malfunction	Contact your dealer for service

Electronic throttle control malfunction	Contact your dealer for service
Mechanical failure	Contact your dealer for service
Possible Lean or Rich Fuel Mixture	Contact your dealer for service
Low or contaminated fuel	Add or change fuel, clean the fuel system
Low octane fuel	Replace with recommended fuel
Clogged fuel filter	Replace fuel filter
Fuel is very high octane	Replace with lower octane fuel

## Engine stops or loses power

Possible Cause	Solution
Out of fuel	Refuel
Kinked or plugged fuel / vent line	Inspect, correct, replace
Water in fuel	Replace with new fuel
Fouled or defective spark plug	Inspect, clean and/or replace spark plug
Worn or defective spark plug wires	Contact your dealer for service
Incorrect spark plug gap or heat	Set gap to specs or replace plug
Loose connections	Check / tighten all connections
Low battery voltage	Recharge battery
Clogged air filter	Inspect and clean or replace
Reverse speedlimiter malfunction	Contact your dealer for service
Electronic throttle control malfunction	Contact your dealer for service
Mechanical failure	Contact your dealer for service

# **EMISSION CONTROL SYSTEM**

<b>SOURCE OF EXHAUST EMISSIONS.....</b>	<b>191</b>
<b>EXHAUST EMISSION CONTROL SYSTEM.....</b>	<b>191</b>
<b>CRANKCASE EMISSION CONTROL SYSTEM</b>	<b>192</b>
<b>NOISE CONTROL SYSTEM... ..</b>	<b>192</b>

## **SOURCE OF EXHAUST EMISSIONS**

The combustion process produces carbon monoxide (CO), nitrogen oxides (NO<sub>x</sub>) and hydrocarbons (HC). Control of hydrocarbons and oxides of nitrogen is very important because, under certain conditions, they react to form photochemical smog when subjected to sunlight. Carbon monoxide does not react in the same way, but it is toxic.

## **EXHAUST EMISSION CONTROL SYSTEM**

The exhaust emission control system includes a PGM-F system and oxygen sensor.

No adjustments to this system should be made although periodic inspection of the components is recommended.

The exhaust emission control system is separate from the crankcase emission control system.

## **CRANKCASE EMISSION CONTROL SYSTEM**

The engine is equipped with a closed crankcase system to prevent discharging crankcase emissions into the atmosphere. Blow-by gas is returned to the combustion chamber through the air cleaner.

## **NOISE CONTROL SYSTEM**

Do not modify the engine, air intake or exhaust components, in order to meet local noise level requirements.



**SEGWAY TECHNOLOGY CO., LTD.**

*[powersports.segway.com](http://powersports.segway.com)*

**DISTRIBUTED BY:**

**Segway Powersports s.r.o.**

Staroplzenecka 290, 326 00, Letkov

Czech Republic

+420 378 21 21 21

[info@segwaypowersports.cz](mailto:info@segwaypowersports.cz)

[www.segwaypowersports.cz](http://www.segwaypowersports.cz)

Segway reserves the right to make any technical changes to the construction and design without prior notice.  
If in doubt, please contact your dealer, or Segway Powersports s.r.o directly.

**© Copyright Segway Powersports s.r.o. 2021**

All information contained within this publication is based on the latest product information at the time of publication. Due to constant improvements in the design and quality, some depictions, information and specifications may differ from those presented in this publication. Depictions and/or procedures in this publication are intended for reference use only. No liability can be accepted for omissions or inaccuracies. Any reprinting or reuse of the depictions and/or procedures contained within, whether whole or in part, is expressly prohibited.